

FAUSTO MİMARİ SİSTEMLER

LS-55 KALDIR & SÜR SİSTEMLERİ

LS-55 LIFT & SLIDE SYSTEMS

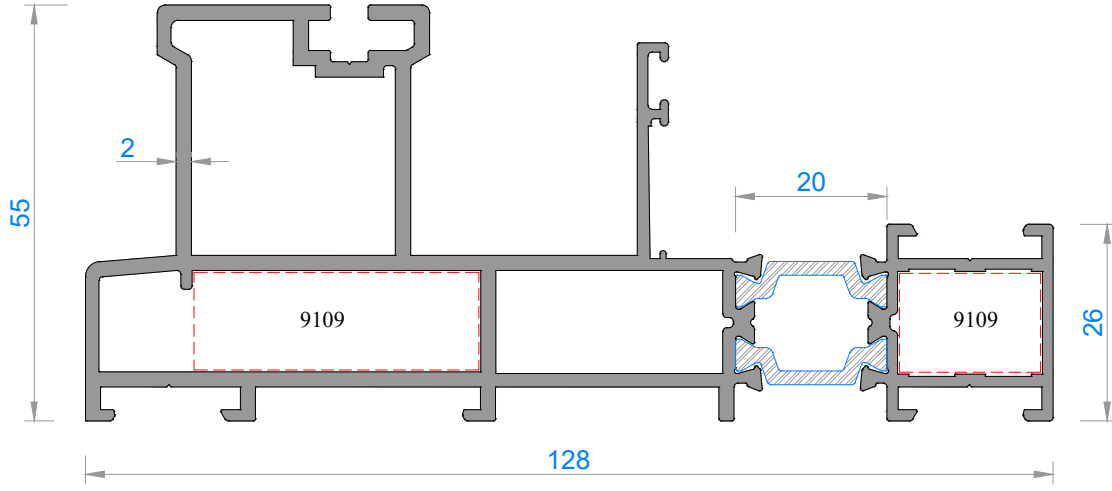

Sistem Kodu	9102-9103
Ağırlık (kg/mt)	2,673
Statik Jx (cm ⁴)	22,41
Statik Jy (cm ⁴)	130,28

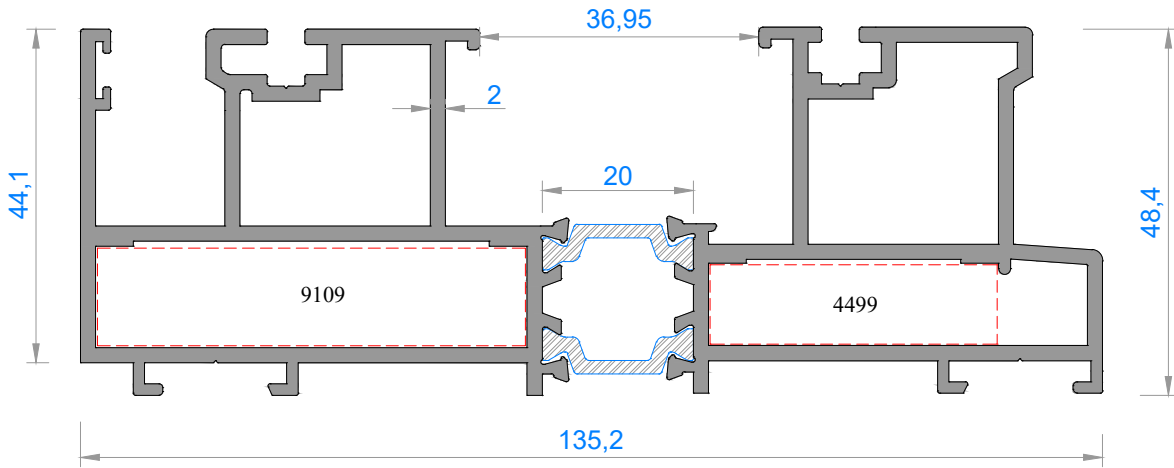

Sistem Kodu	9200-9201*
Ağırlık (kg/mt)	3,268
Statik Jx (cm ⁴)	26,89
Statik Jy (cm ⁴)	211,34

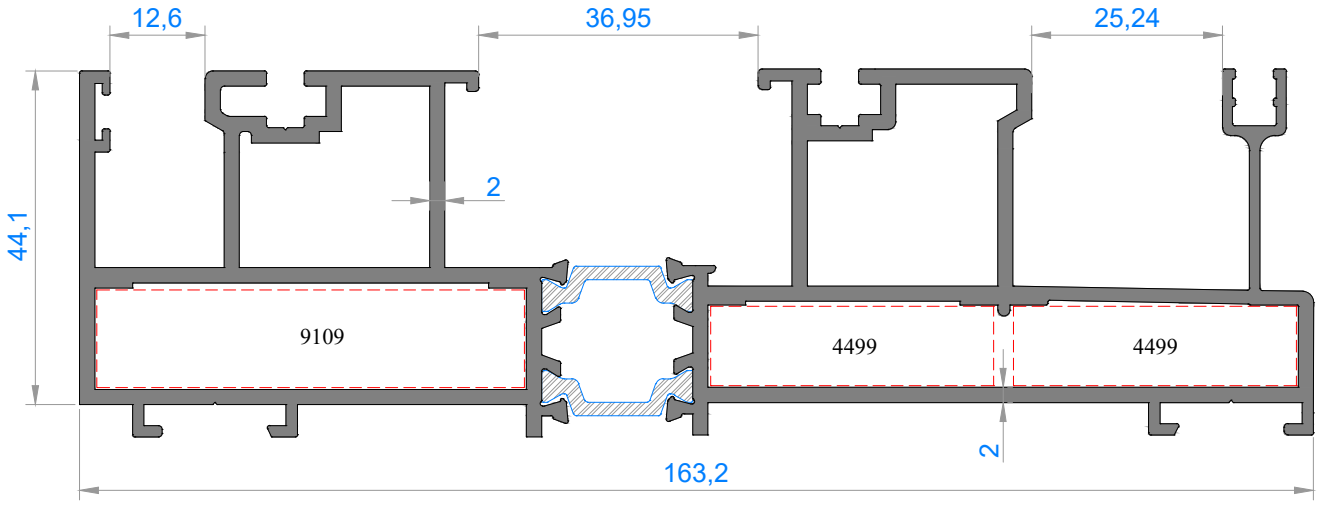
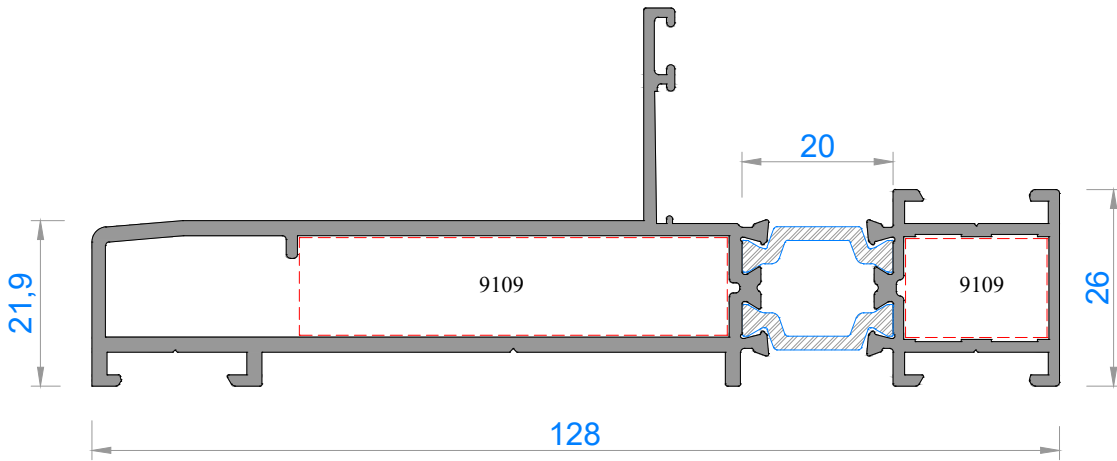
Sistem Kodu 9200-9203
Ağırlık (kg/mt) 3,746
Statik Jx (cm⁴) 32,00
Statik Jy (cm⁴) 337,60

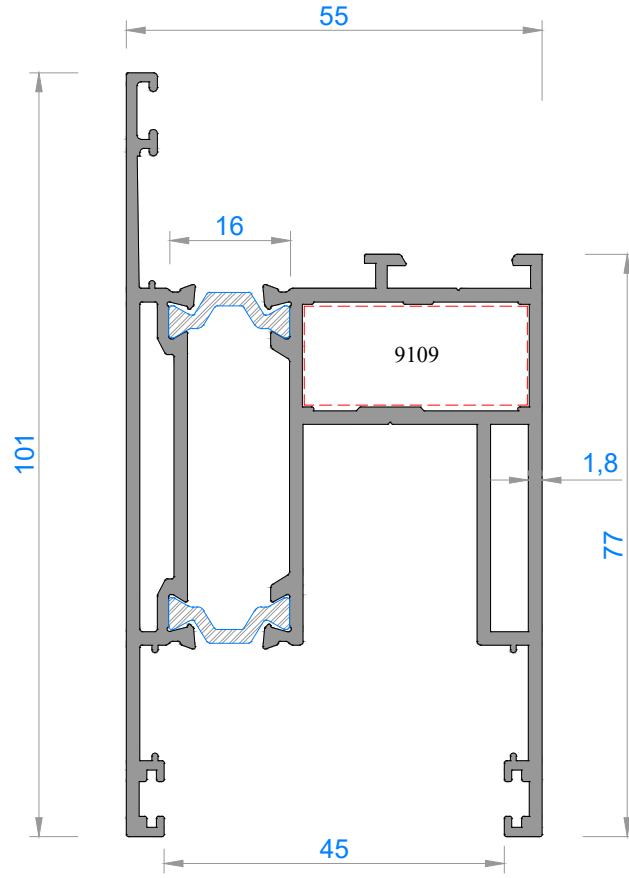
Sistem Kodu 9215-9103*
Ağırlık (kg/mt) 1,954
Statik Jx (cm⁴) 6,87
Statik Jy (cm⁴) 101,41

**Sistem Kodu 9100-9101**

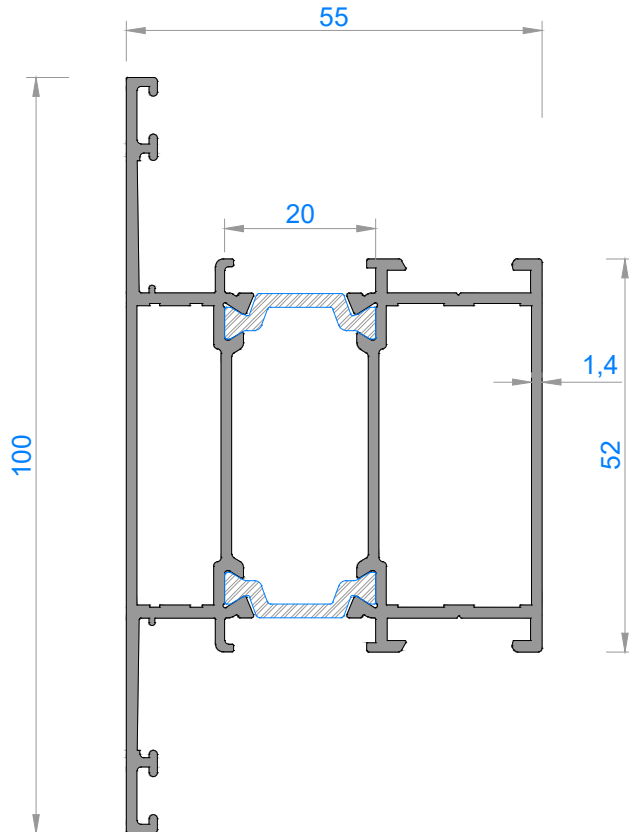
Ağırlık (kg/mt) 2,185

Statik Jx (cm⁴) 42,91Statik Jy (cm⁴) 31,94**Sistem Kodu 9104-9105**

Ağırlık (kg/mt) 1,631

Statik Jx (cm⁴) 27,94Statik Jy (cm⁴) 21,54

NOT: Profil ağırlıkları teoriktir, üretim sonrası ağırlıklar geçerlidir.

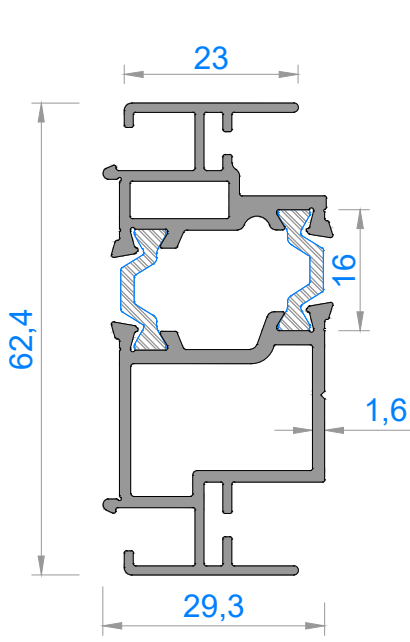

Sistem Kodu	9216-9217
Ağırlık (kg/mt)	1,170
Statik Jx (cm ⁴)	13,90
Statik Jy (cm ⁴)	3,00

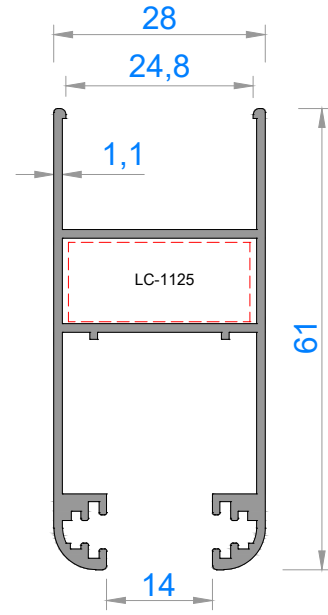

Sistem Kodu	4906
Ağırlık (kg/mt)	0,680
Statik Jx (cm ⁴)	7,80
Statik Jy (cm ⁴)	3,33

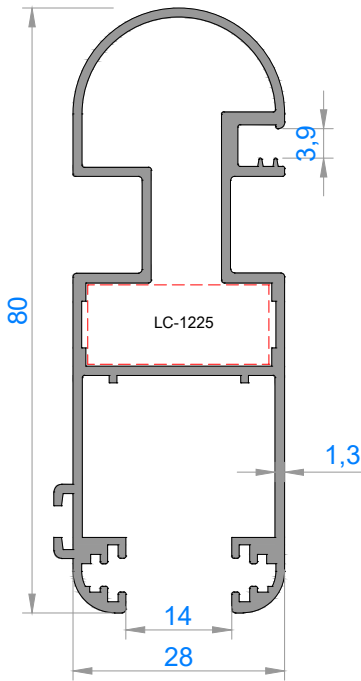

Sistem Kodu	7611
Ağırlık (kg/mt)	0,992
Statik Jx (cm ⁴)	20,40
Statik Jy (cm ⁴)	4,10

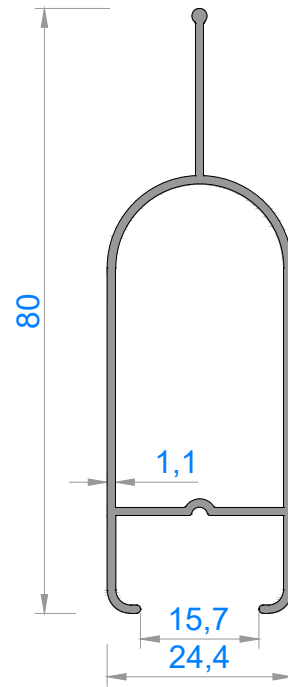

Sistem Kodu	7612*
Ağırlık (kg/mt)	0,532
Statik Jx (cm ⁴)	9,38
Statik Jy (cm ⁴)	1,77

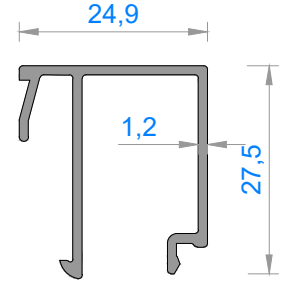
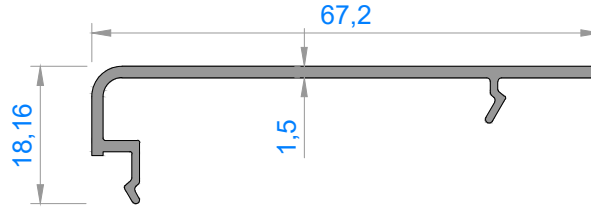
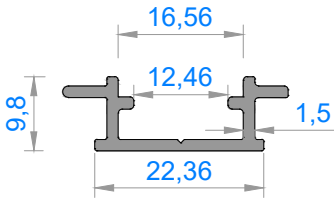
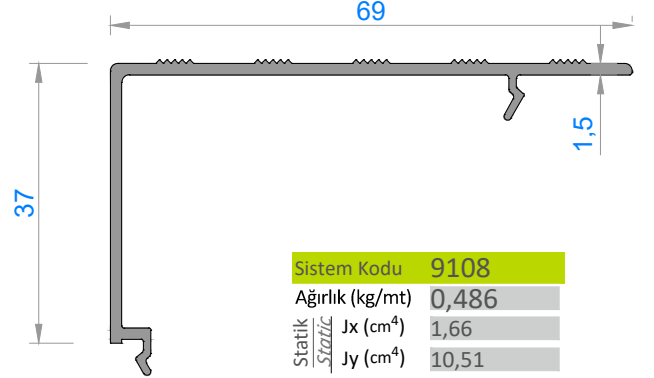
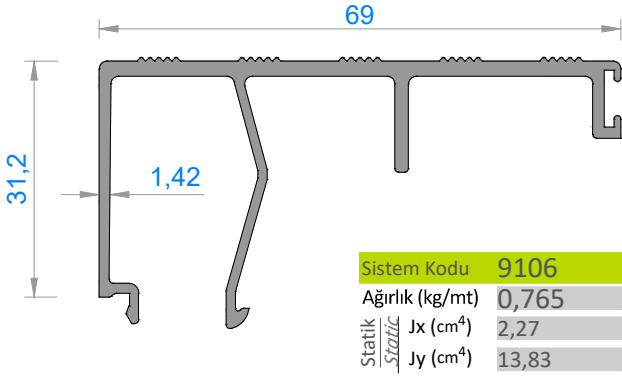

Sistem Kodu	9114*
Ağırlık (kg/mt)	0,216

Sistem Kodu	9107
Ağırlık (kg/mt)	0,375

Sistem Kodu	9010
Ağırlık (kg/mt)	0,309

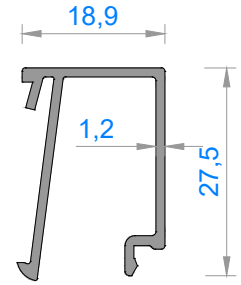
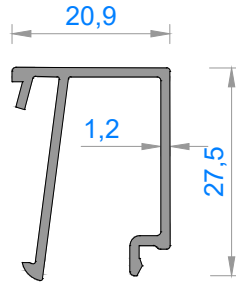
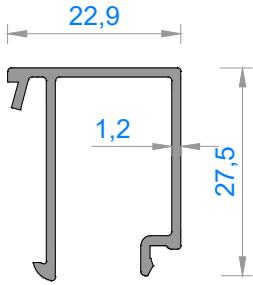

Sistem Kodu	9117*
Ağırlık (kg/mt)	0,288

Sistem Kodu	9118*
Ağırlık (kg/mt)	0,282

Sistem Kodu	9119*
Ağırlık (kg/mt)	0,275

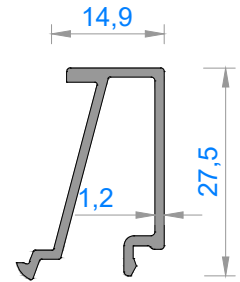
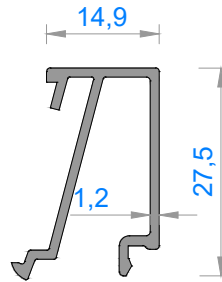
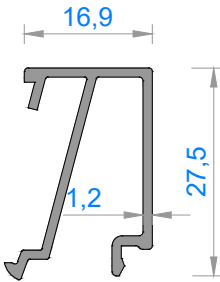

Sistem Kodu	9110*
Ağırlık (kg/mt)	0,277

Sistem Kodu	9111*
Ağırlık (kg/mt)	0,271

Sistem Kodu	9112*
Ağırlık (kg/mt)	0,255

CAM,ÇITA ve CONTA SEÇENEKLERİ

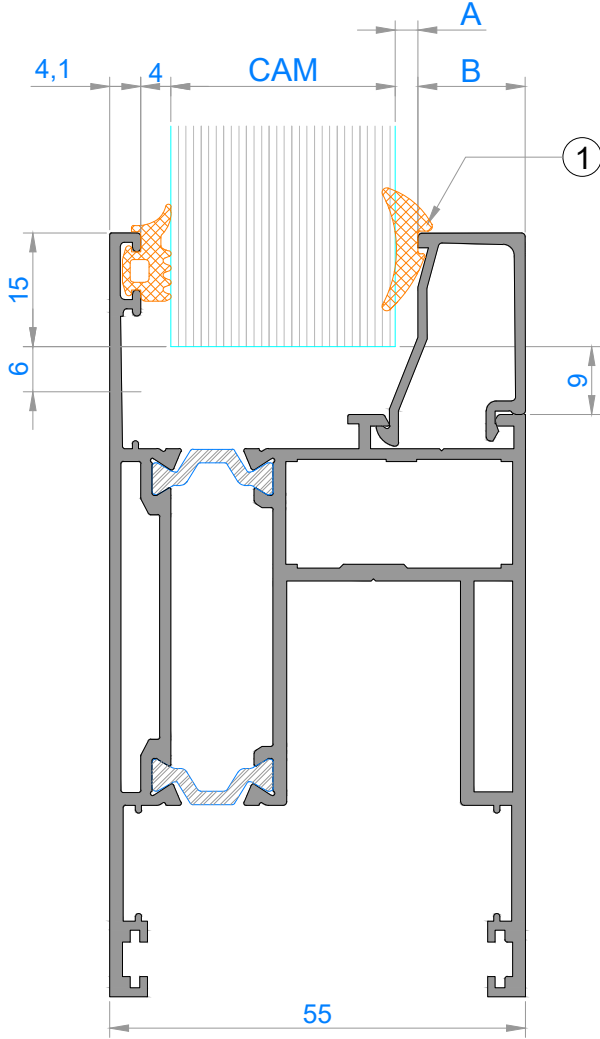



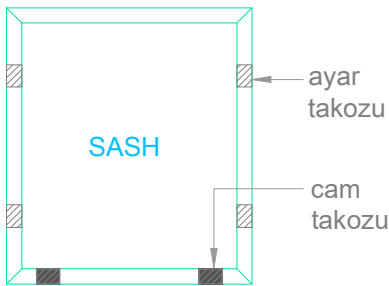

CAM,ÇITA ve CONTA SEÇENEKLERİ

CAM mm	CONTA		ÇITA	
	A : mm	KOD	B : mm	KOD
20	4,7	AYK-02	22,2	9010
22	3,7	AYK-03	22,2	9117
24	2,7	AYK-04	22,2	9118
26	4	AYK-03	18,9	9119
28	4,6	AYK-02	16,2	9110
30	4,7	AYK-04	16,2	9111
32	2,7	AYK-04	14,2	9112

Tabloda gösterilen conta ve boşluklar ile ilgili veriler teoriktir.Lütfen cam ve conta toleranslarının değişkenlik gösterebileceğini dikkate alınız.



4mm	3mm	4mm	5mm
			
SC103-1	AYK-04	AYK-03	AYK-02



CAM TAKOZU-cam takozlari yerlesimi üstte bulunan sematik çizimde gösterilmistir. takozların kenara mesafeleri kanat ölçüsünün 5/1 i yada 10/1 i kadar olmalıdır.

MESAFE AYARLAMA TAKOZU-mesafe ayar takozlari camin alüminyum çerçeve içinde doğru pozisyonda stabil olarak durmasını sağlar. cam ile profil arasına takozlari zorlamadan yerleştiriniz.

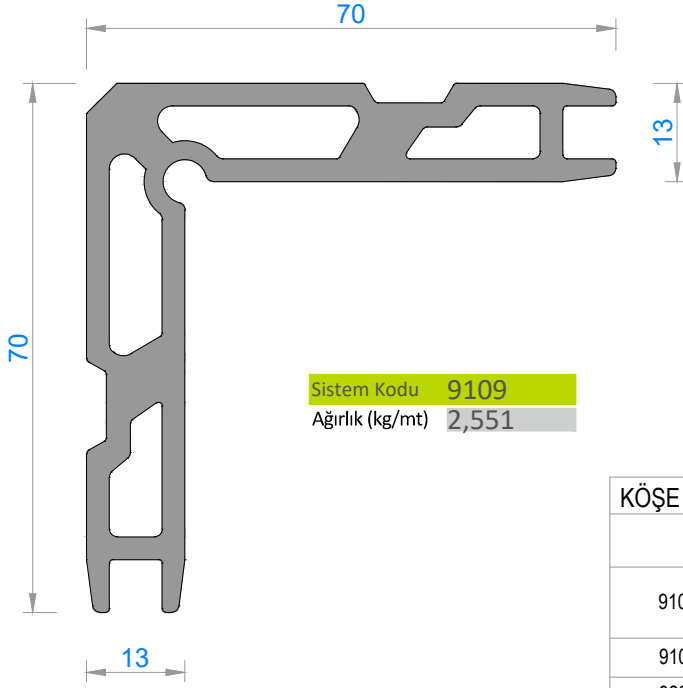
Takozlar ahsap yada plastik malzemeden yapılabilir. cam takozu sertligi 70-75 shore mesafe ayarlama takozu sertligi 50-60 shore olmalıdır. takoz uzunlugu= Min. 50mm olmalıdır. takoz genisligi=cam kalınlıgından büyük olmalı,takoz kalınlıgı=belirtilen esit bosluk ölçülerinde



Sistem Kodu **9109**

Ağırlık (kg/mt) **2,551**
KÖŞE TAKOZLARI (CORNER JOINT)

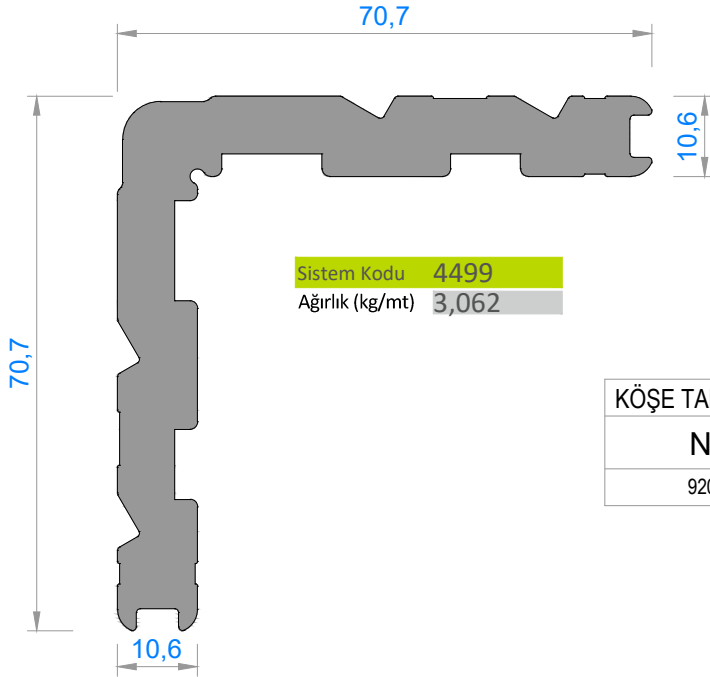
Nr	 L m	 AKS. KODU ACS. CODE	KESİM ÖLÇÜSÜ CUTTING SIZE
9102-9103	9109	9109-37,6	37,6 mm
	9109	9109-18,7	18,7 mm
9100-9101	9109	9109-29,5	29,5 mm
9200	9109	9109-56,6	56,6 mm



Sistem Kodu **4499**



Ağırlık (kg/mt) **3,062**
KÖŞE TAKOZLARI (CORNER JOINT)

Nr	 L m	 AKS. KODU ACS. CODE	KESİM ÖLÇÜSÜ CUTTING SIZE
9201	4499	4499-38	38 mm

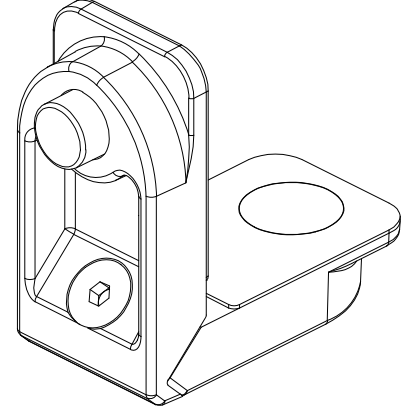
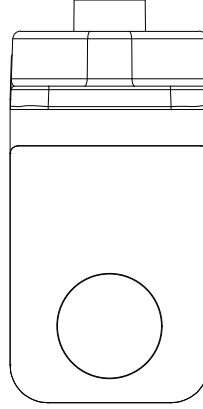
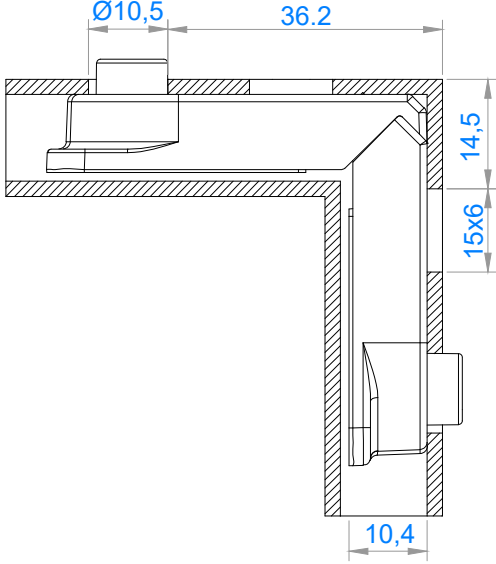

LC - 1125

LC - 1125

KÖŞE TAKOZLARI (CORNER JOINT)

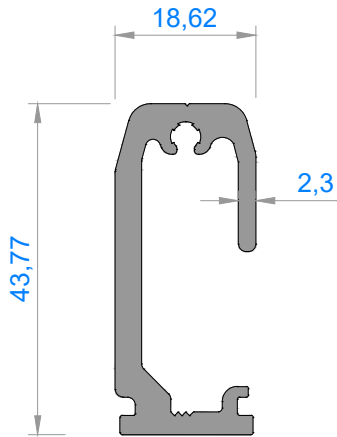
Nr	 L m	 AKS. KODU ACS. CODE	KESİM ÖLÇÜSÜ CUTTING SIZE
9213	----	LC-1125	10,5X24mm
4906	----	LC-1125	10,5X24mm

ORTA KAYIT BAĞLANTI (MULLION CONNECTION PIECE)

Nr	 L m	 AKS. KODU ACS. CODE	KESİM ÖLÇÜSÜ CUTTING SIZE
9104-9105	9113	9113-39	39 mm
9104-9113	9113	9113-39	39 mm

Sistem Kodu **9113**

Ağırlık (kg/mt) **0,812**

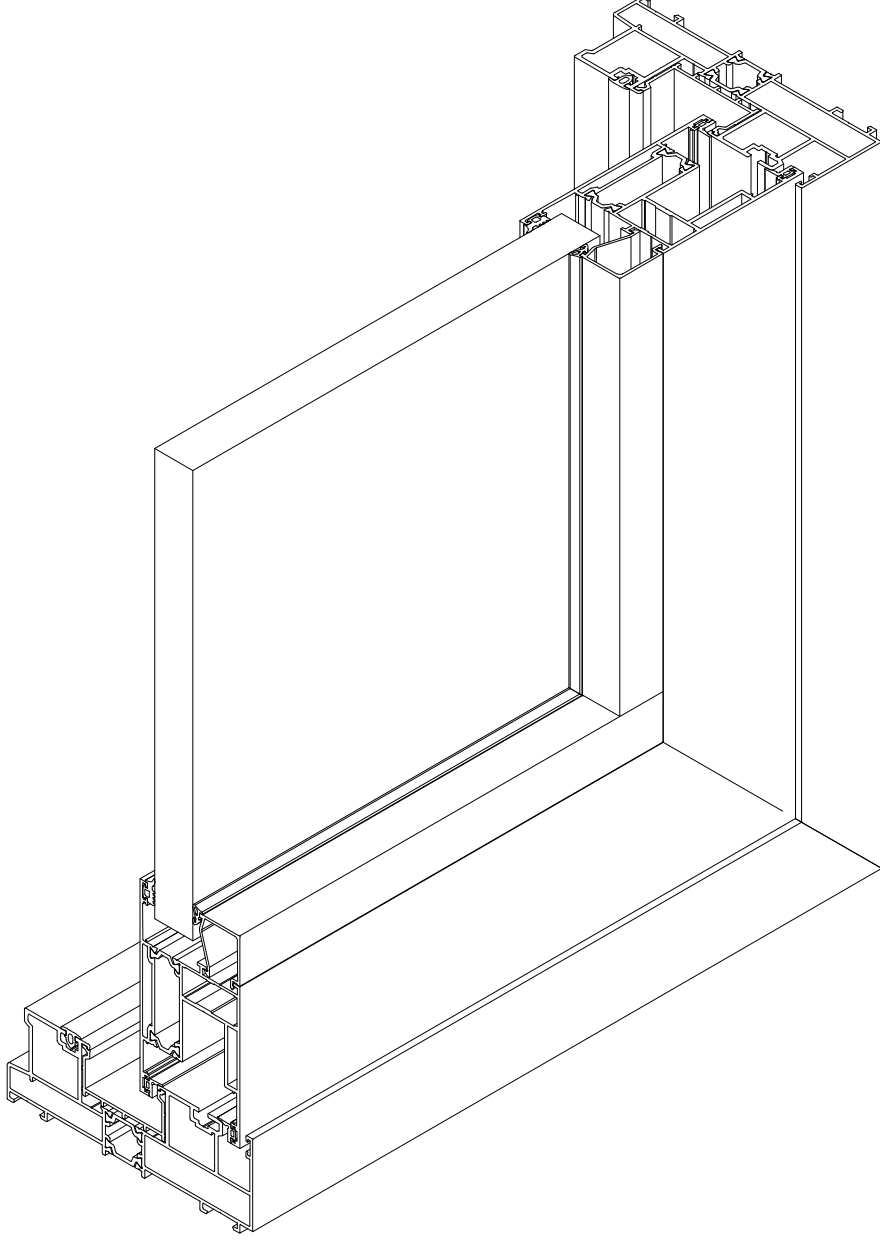
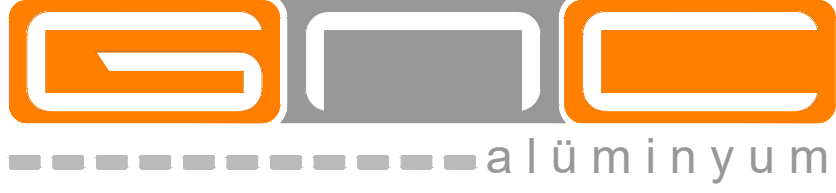

FAUSTO MİMARİ SİSTEMLER

LS-55 SİSTEM DETAYLARI

LS-55 SYSTEM DETAILS

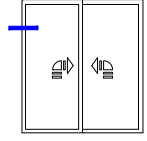

*cam kombinasyon sayfasına bakınız.

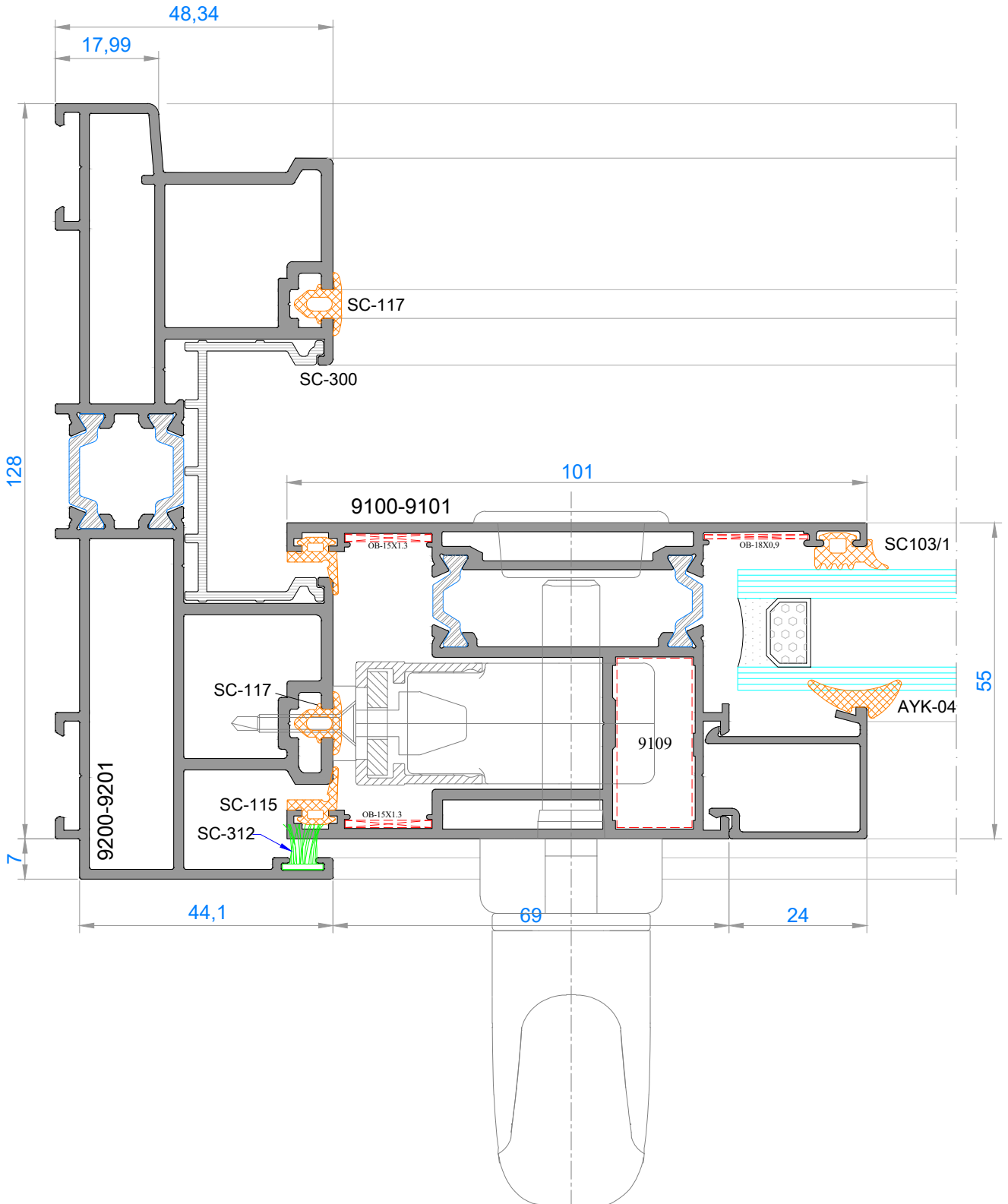

NOT: Profil ağırlıkları teoriktir, üretim sonrası ağırlıklar geçerlidir.

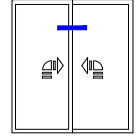

*cam kombinasyon sayfasına bakınız.

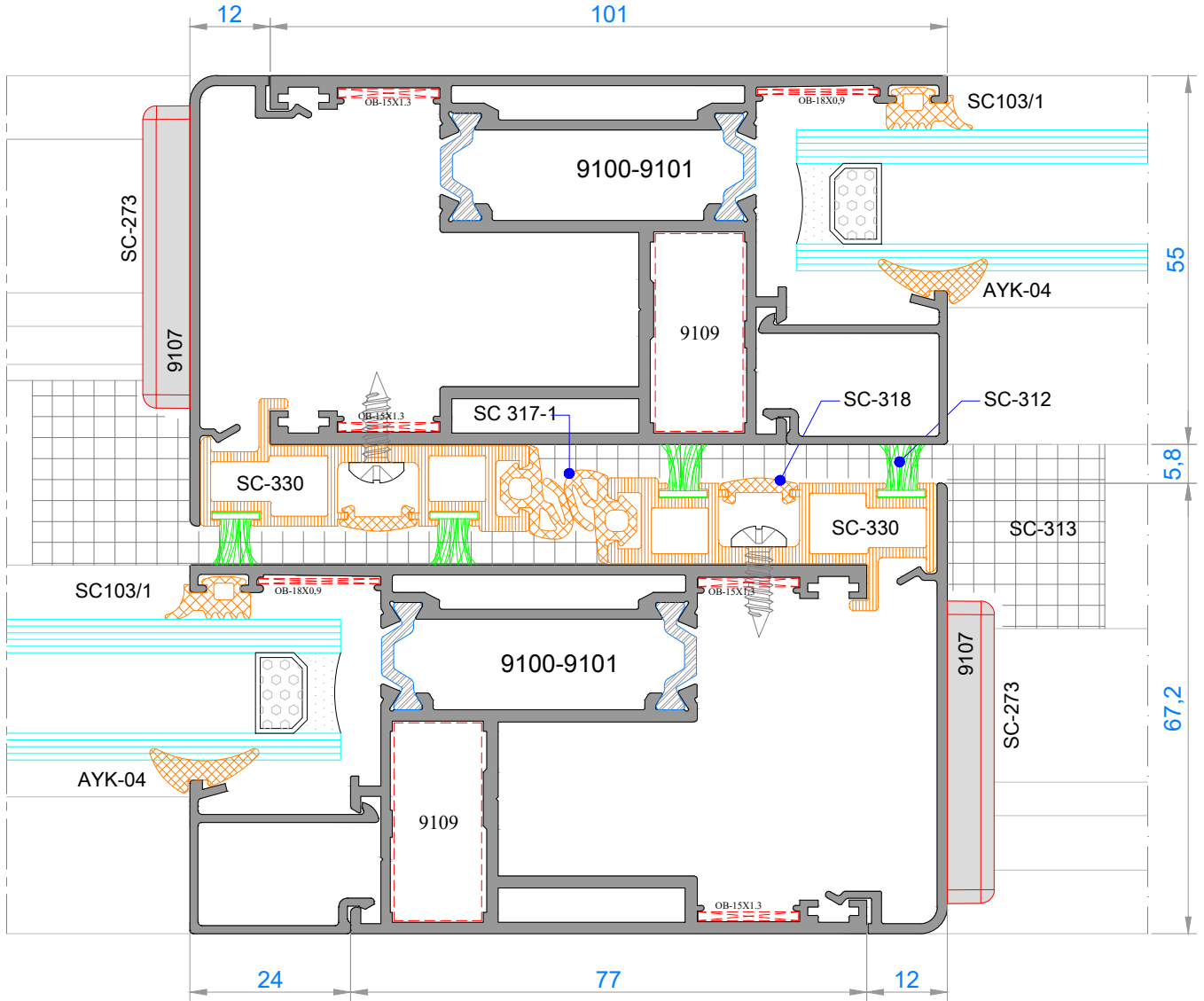

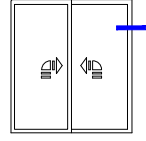

*cam kombinasyon sayfasına bakınız.

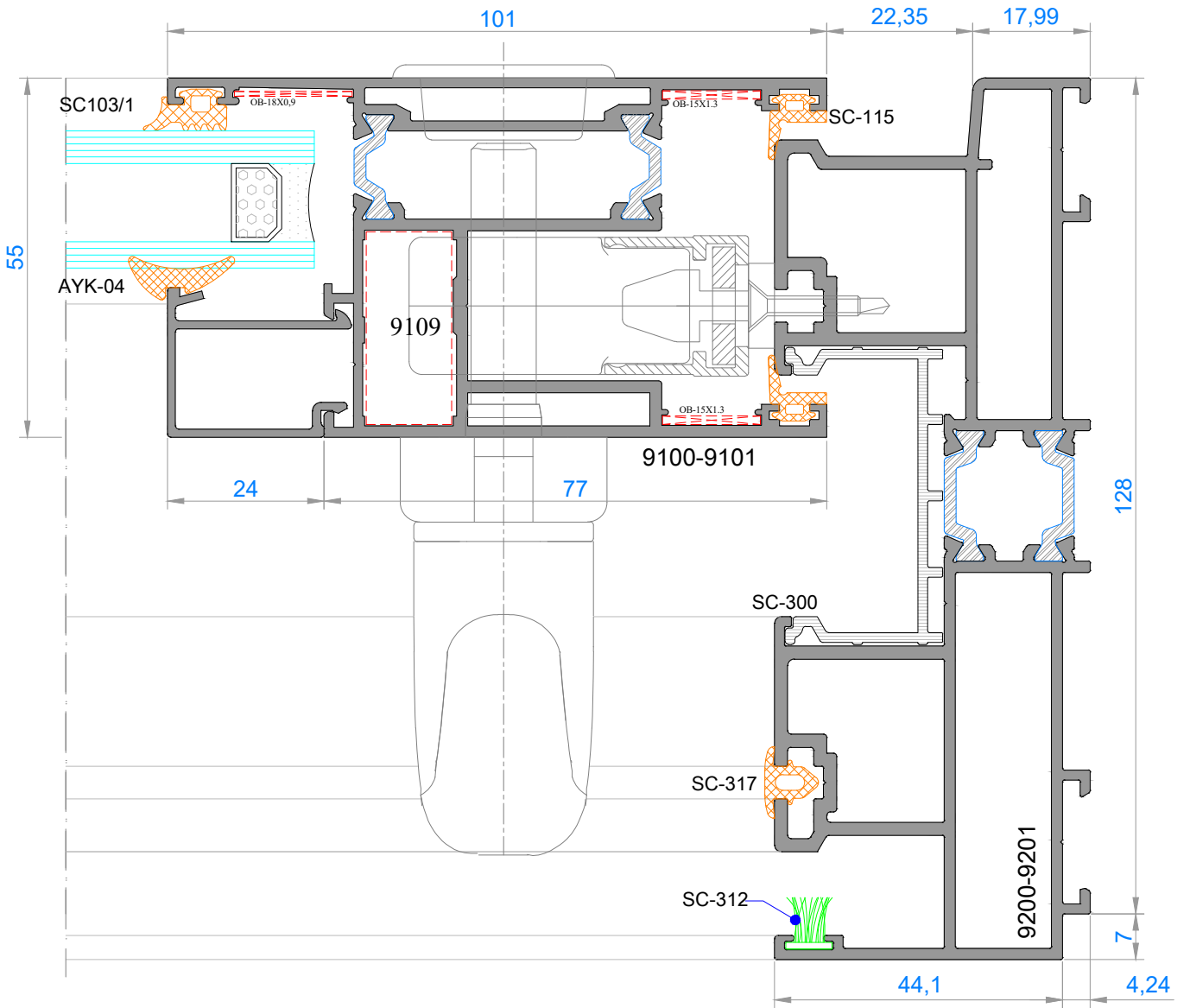

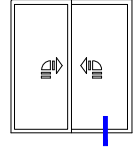

*cam kombinasyon sayfasına bakınız.

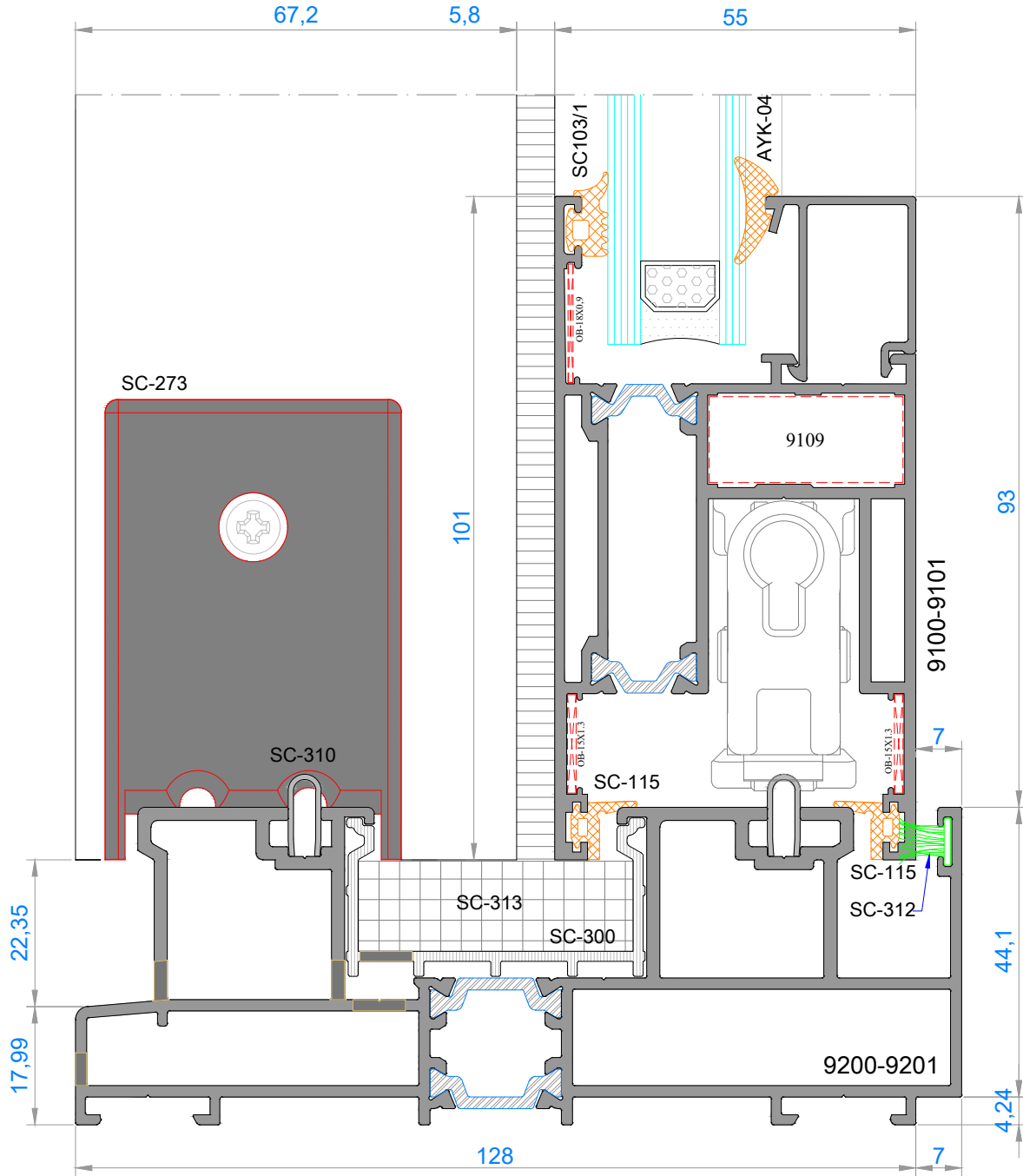

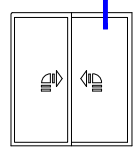

*cam kombinasyon sayfasına bakınız.

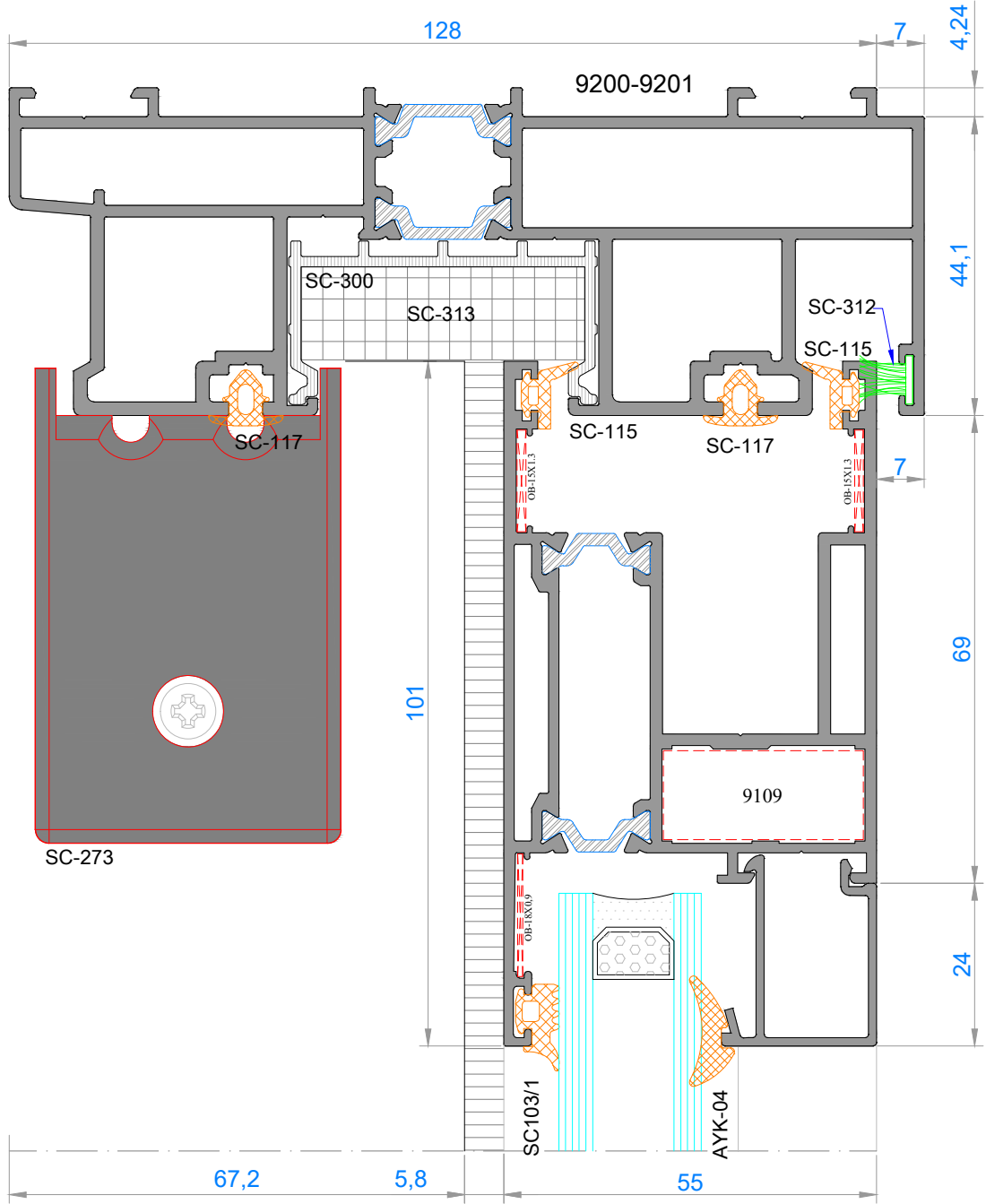

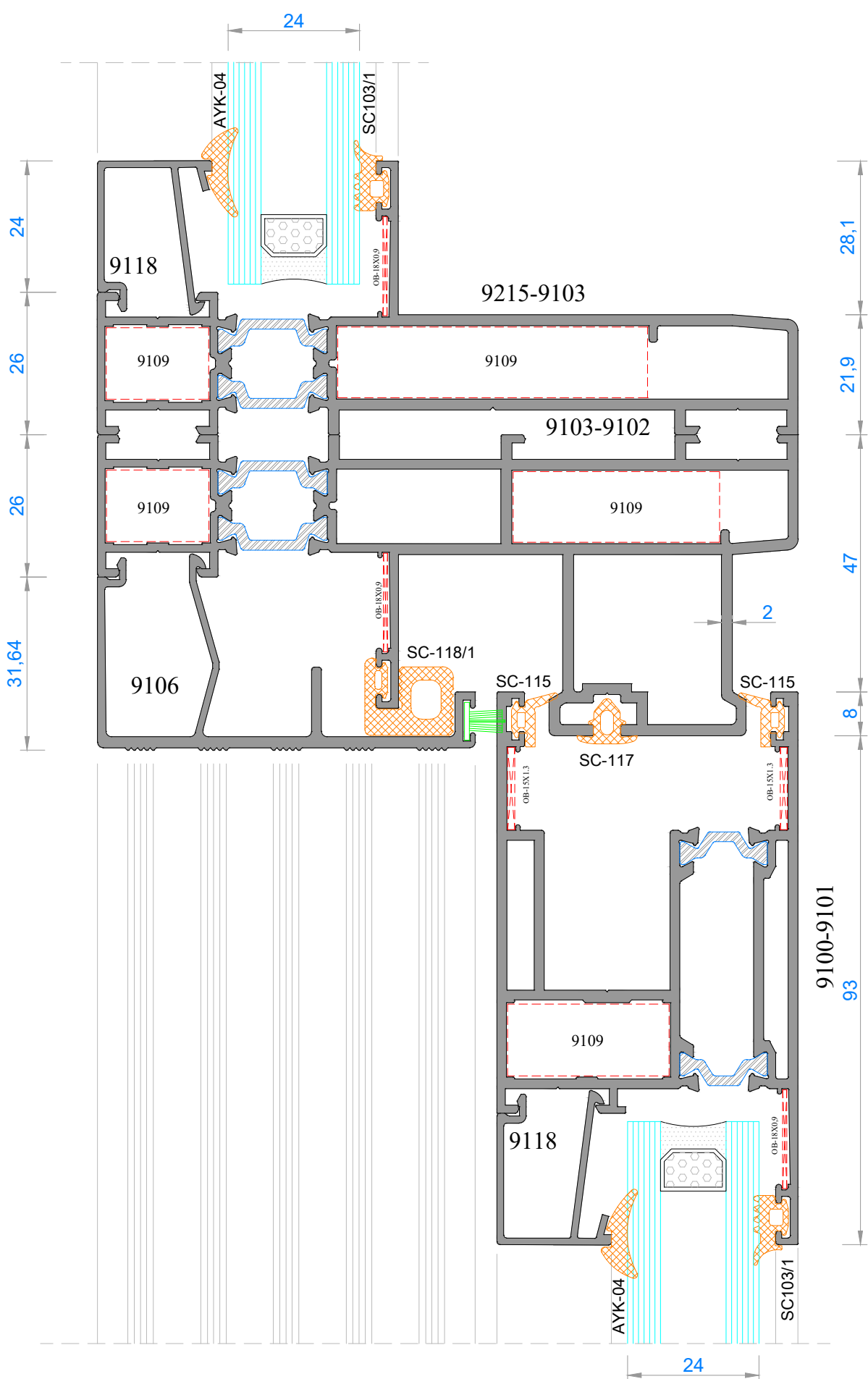

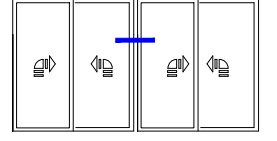
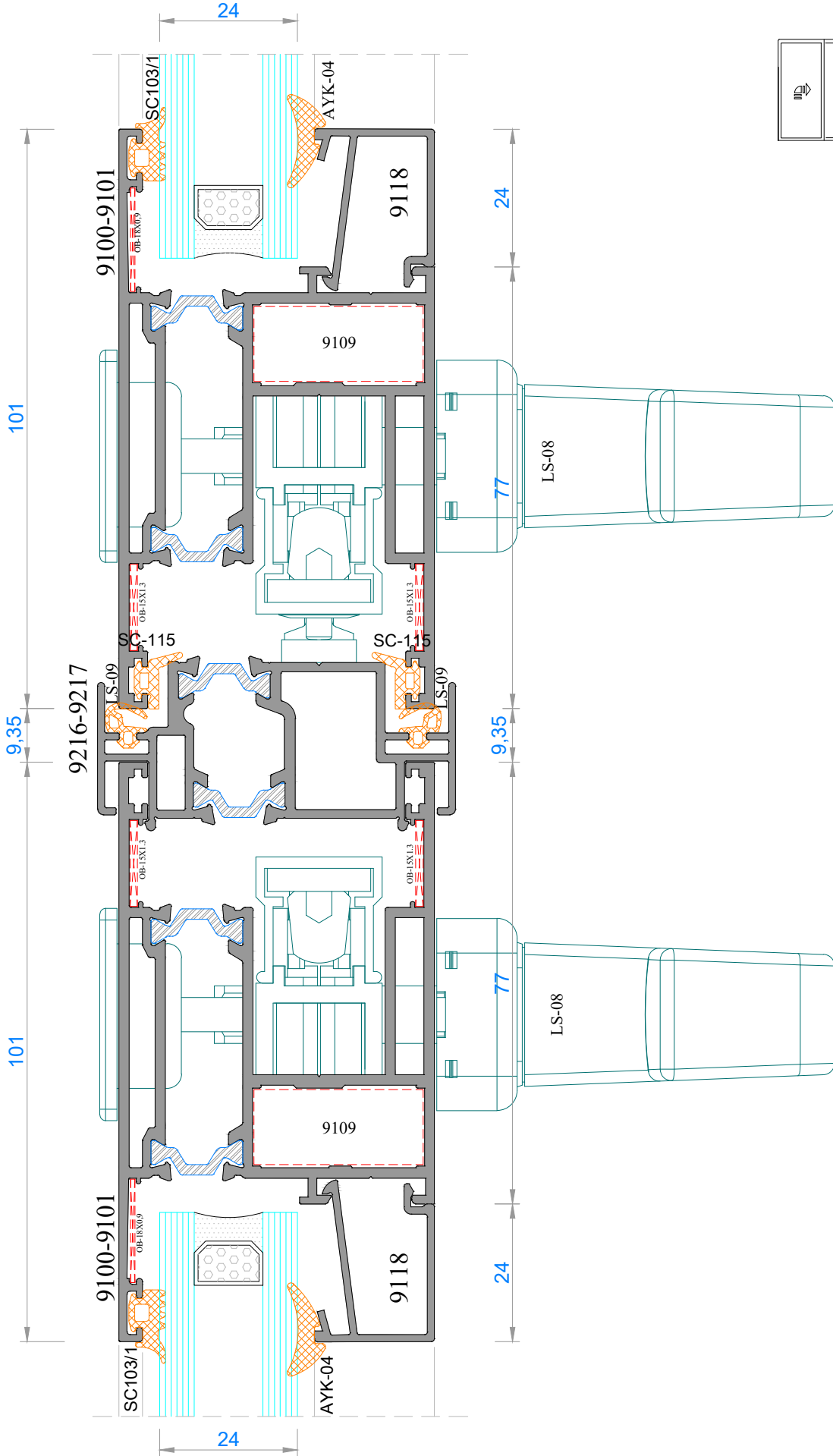

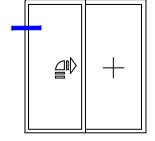

*cam kombinasyon sayfasına bakınız.

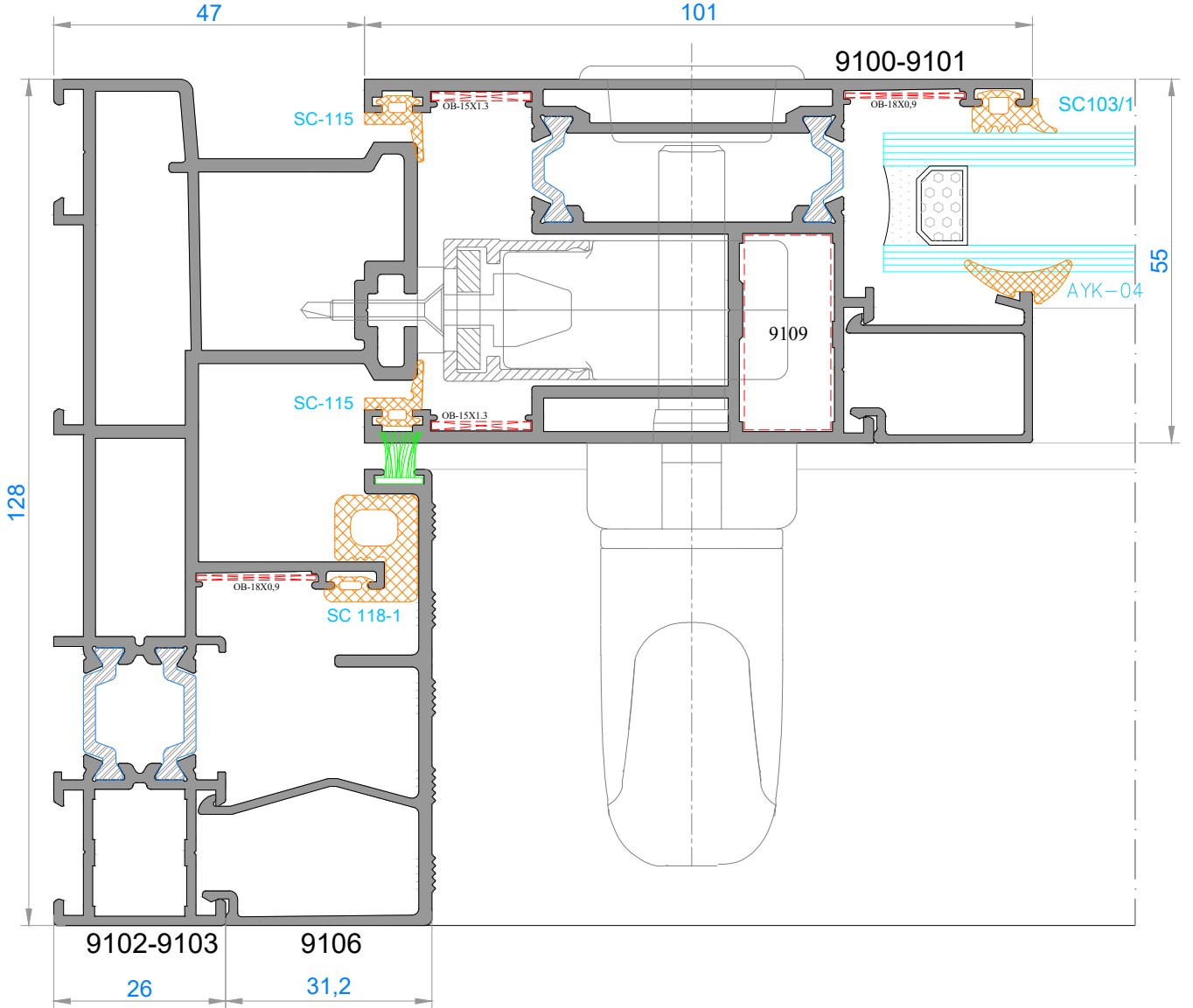

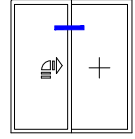

*cam kombinasyon sayfasına bakınız.

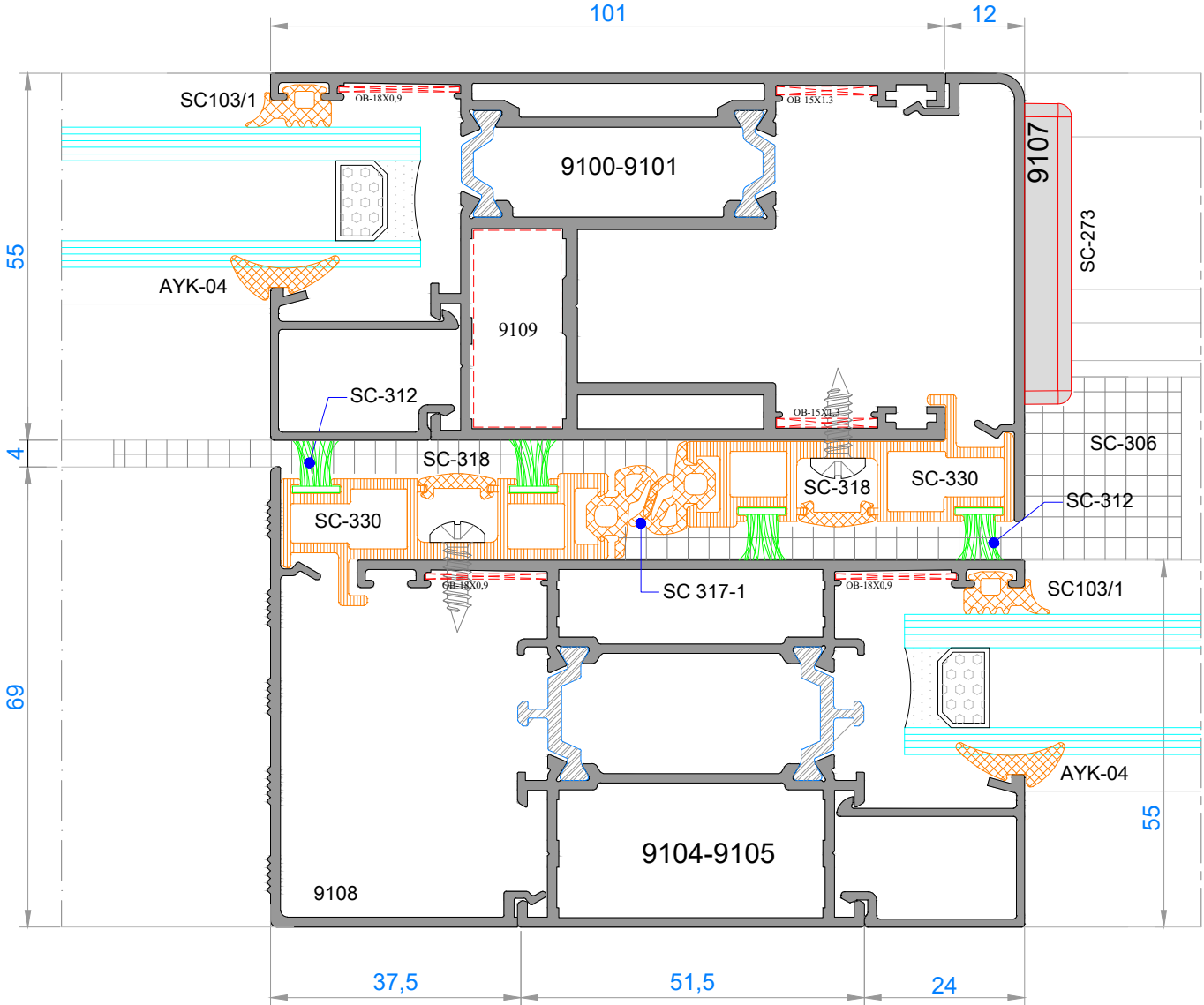

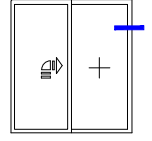

*cam kombinasyon sayfasına bakınız.

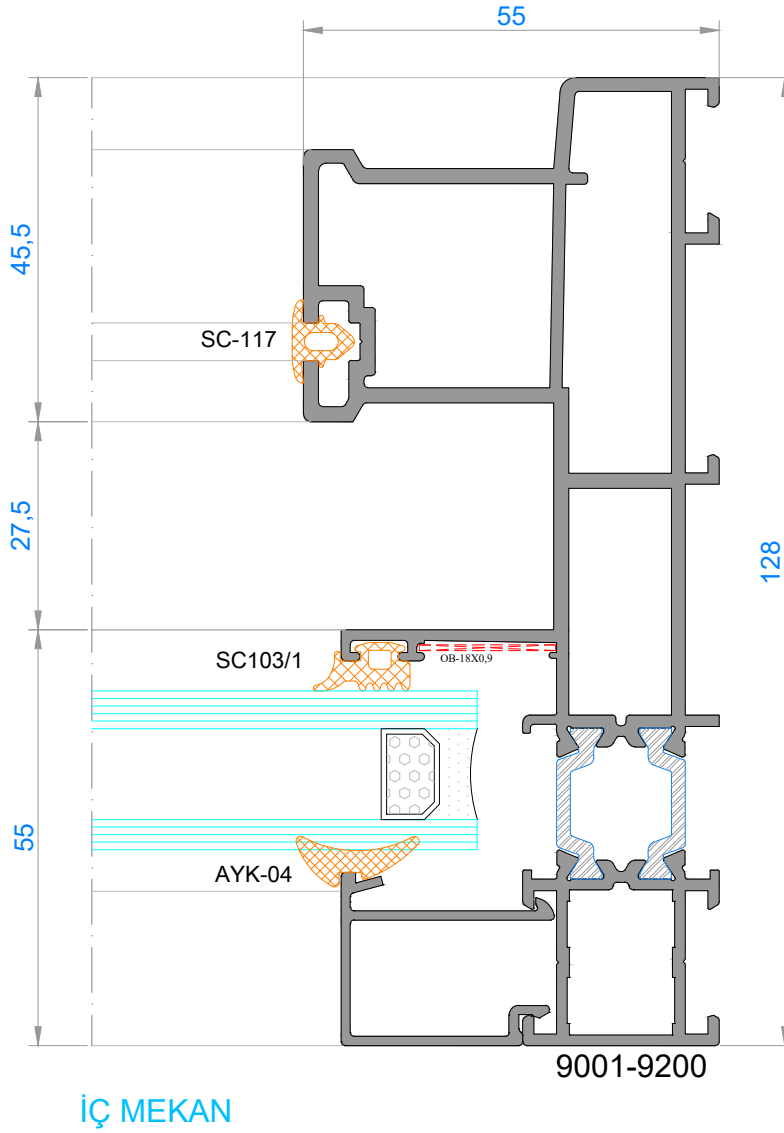

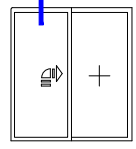

*cam kombinasyon sayfasına bakınız.

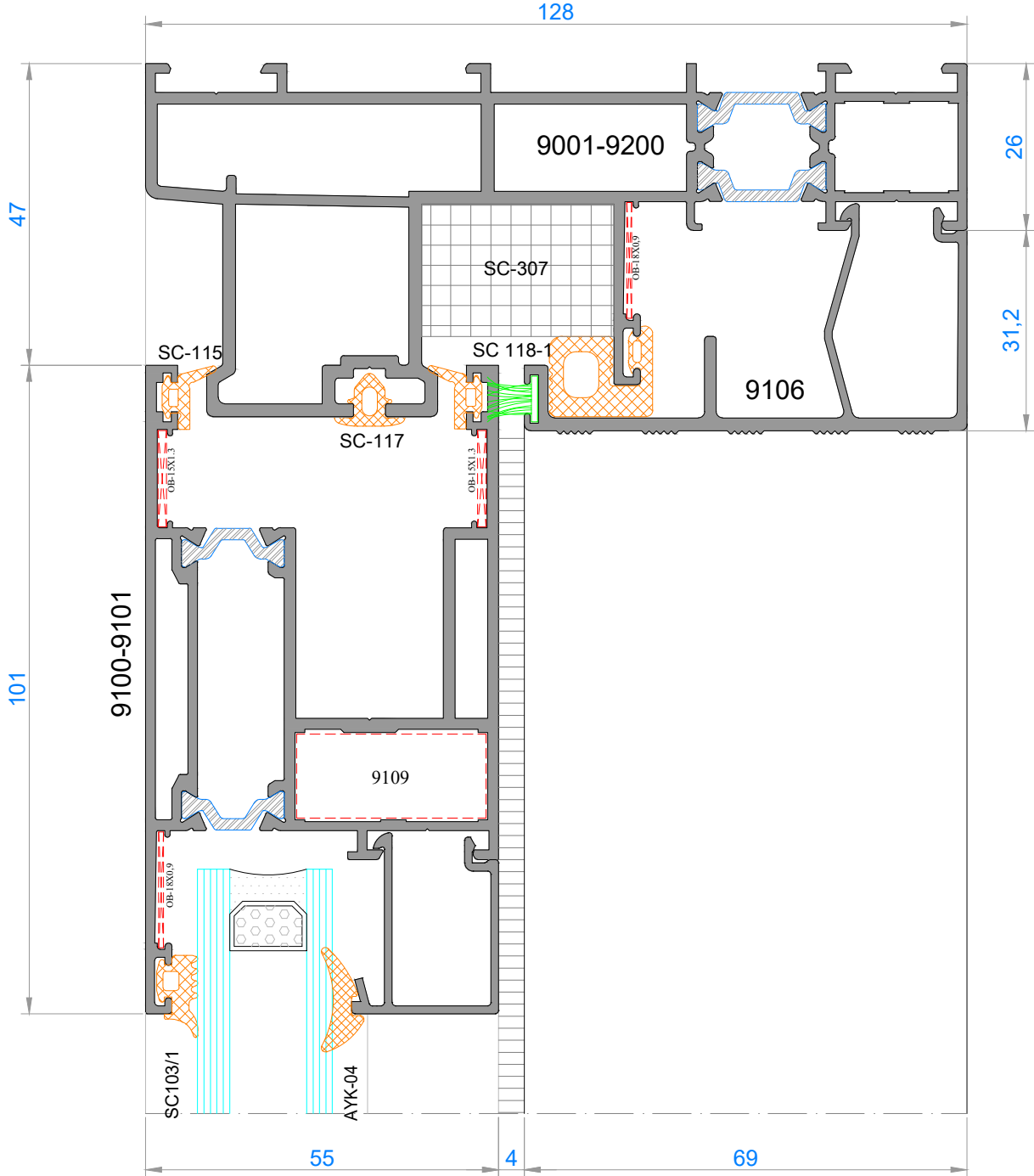

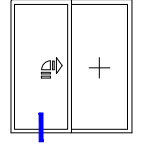

*cam kombinasyon sayfasına bakınız.

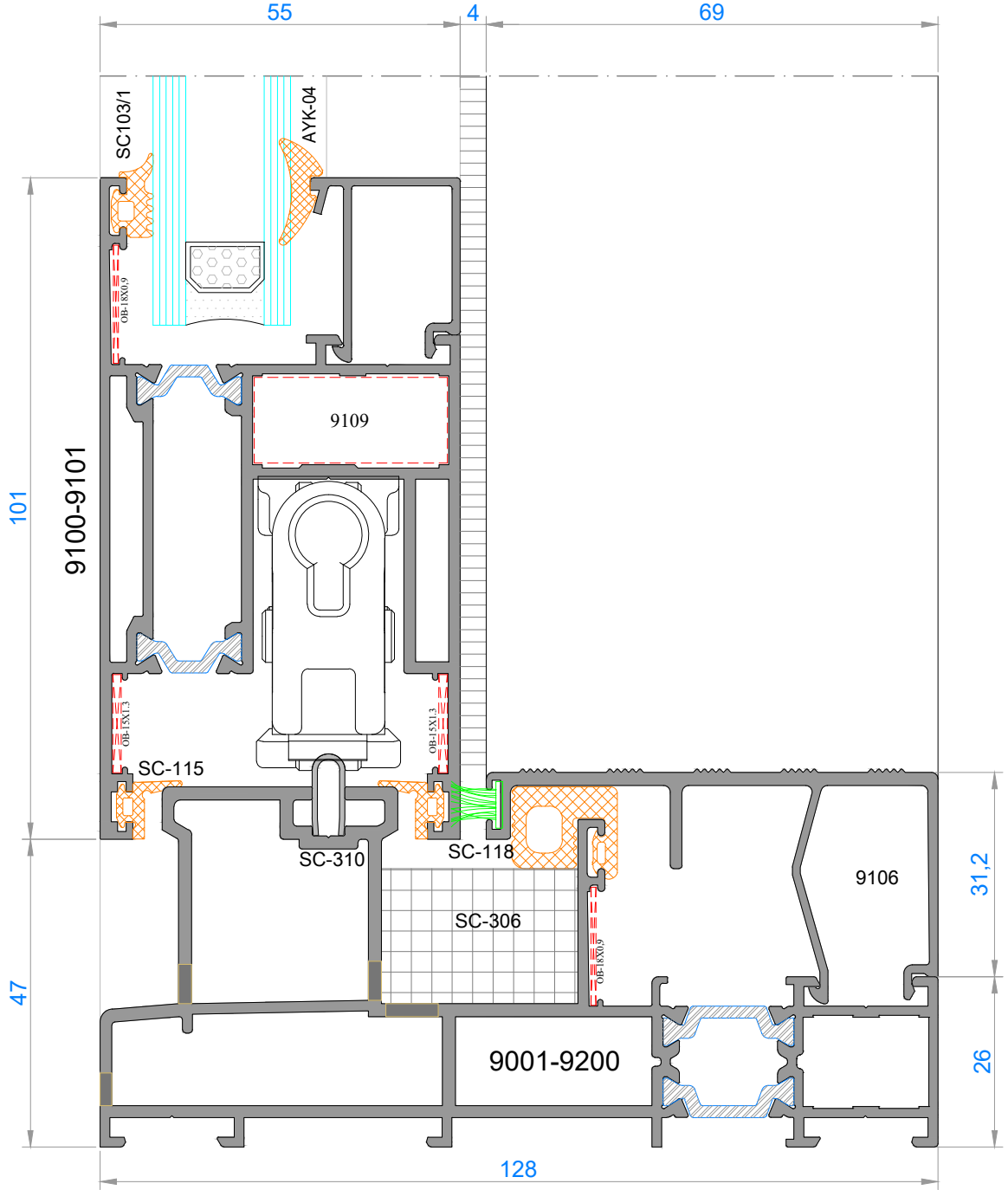

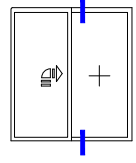

*cam kombinasyon sayfasına bakınız.

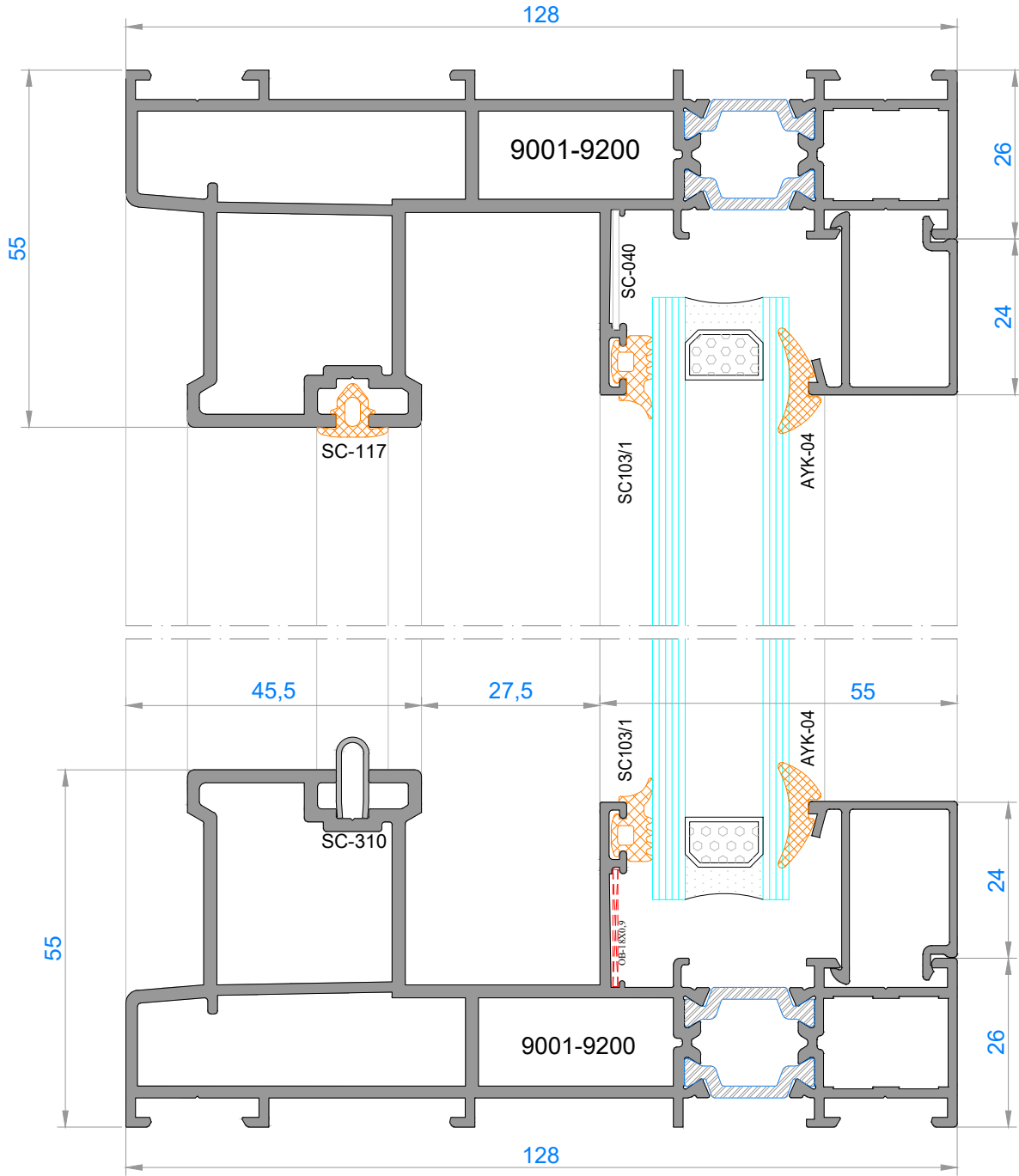

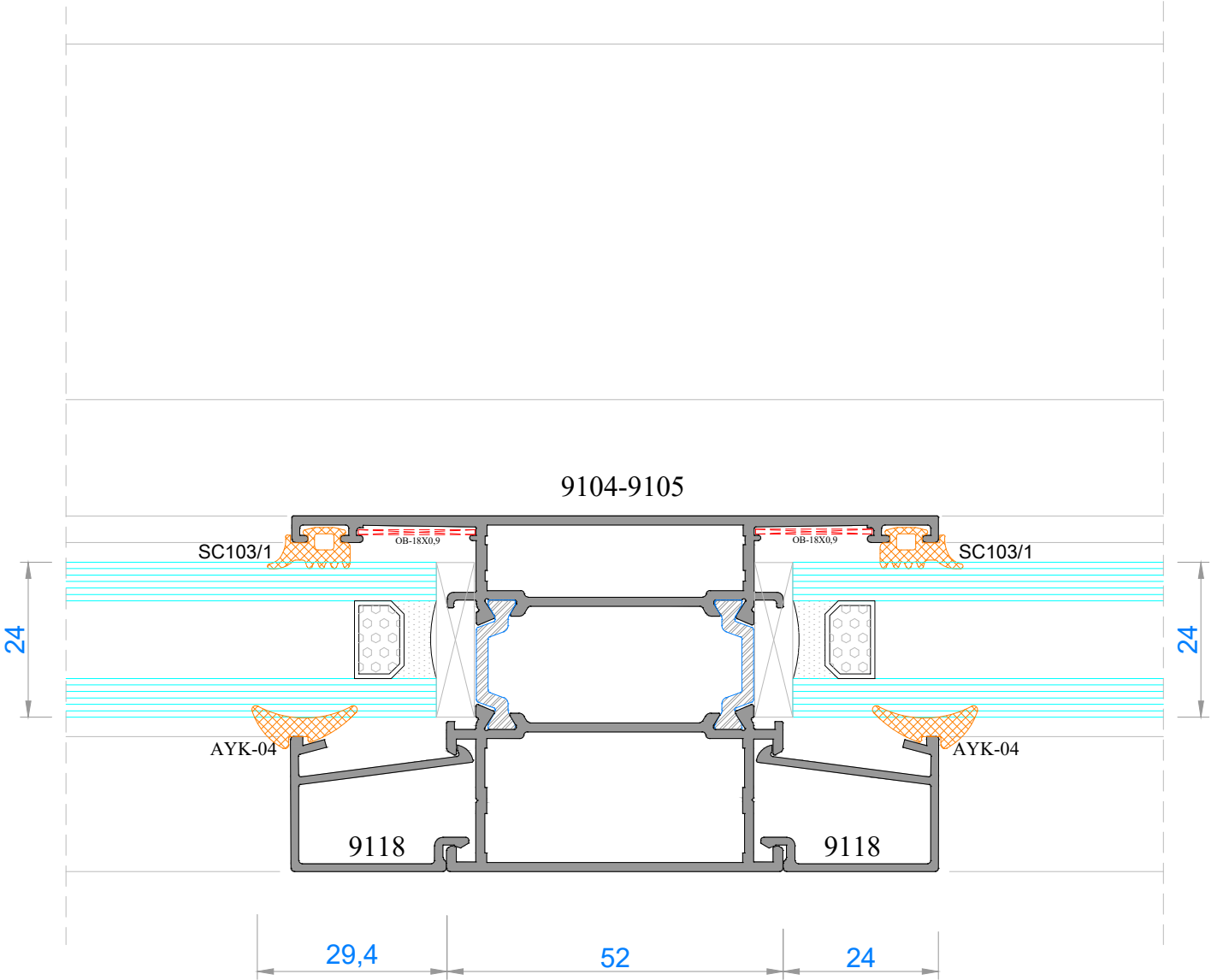
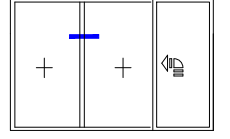

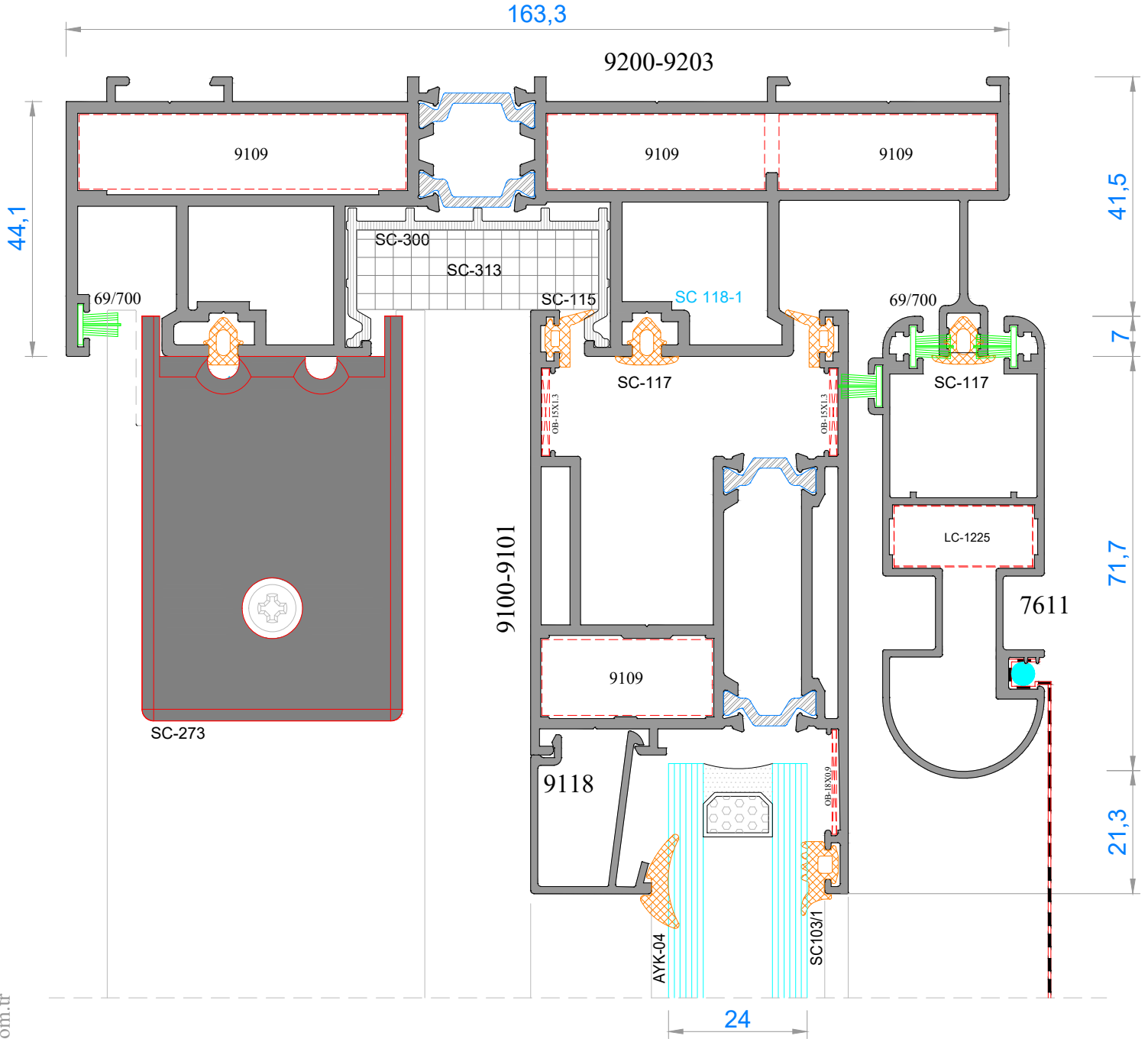
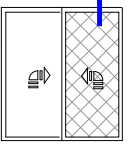

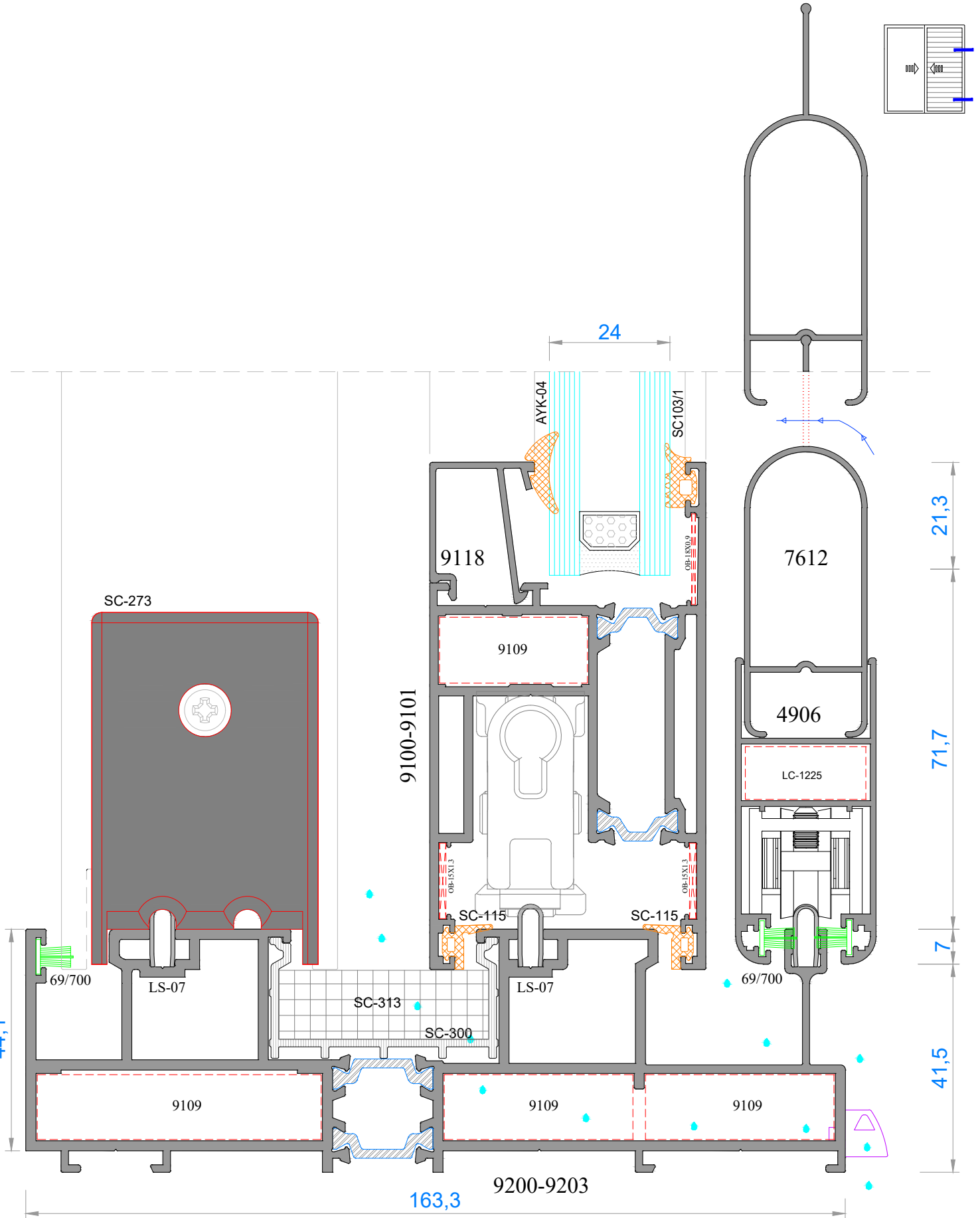

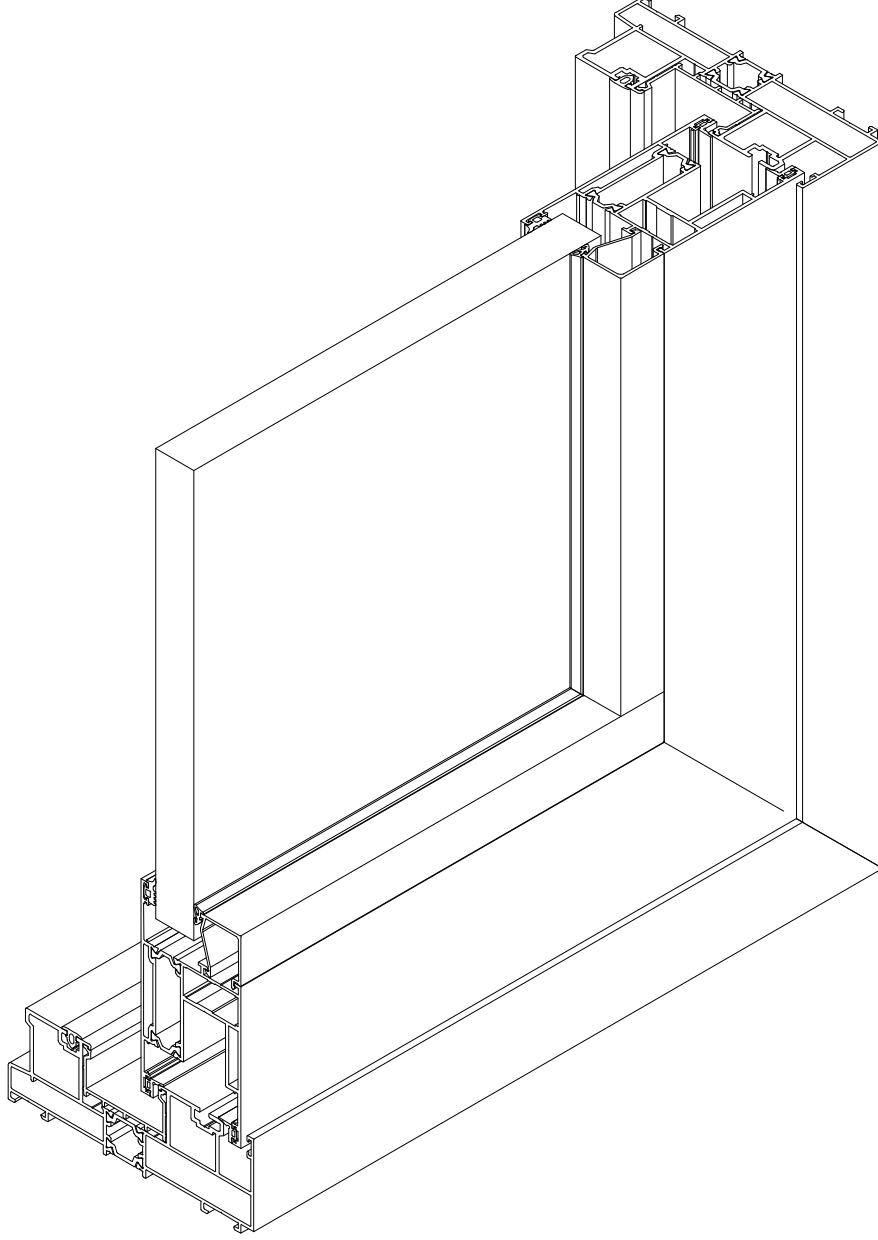
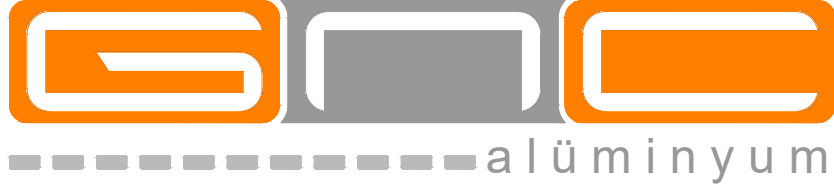

FAUSTO MİMARİ SİSTEMLER

LS-55 KURULUM VE ÜRETİM ŞEMALARI

LS-55 INSTALLATION AND PRODUCTION SCHEME

AÇILIM TIPLERİ - OPENING TYPES

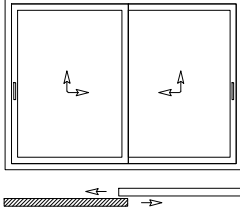

2 HAREKETLİ KANAT
2 SLIDING SASH

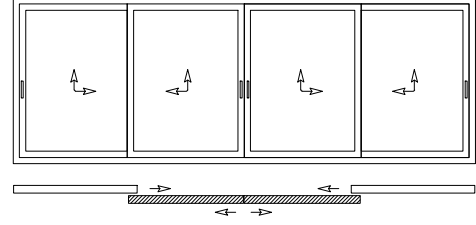

4 HAREKETLİ KANAT
4 SLIDING SASH

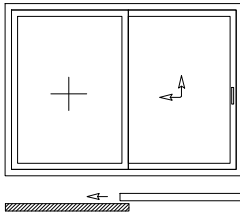

1 HAREKETLİ 1 SABİT KANAT
1 SLIDING 1 FIX SASH

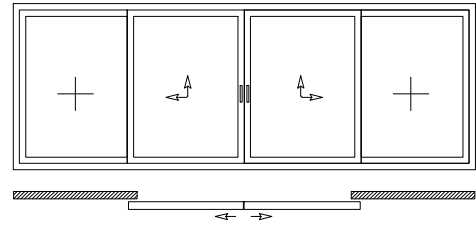

2 HAREKETLİ 2 SABİT KANAT
2 SLIDING 2 FIX SASH

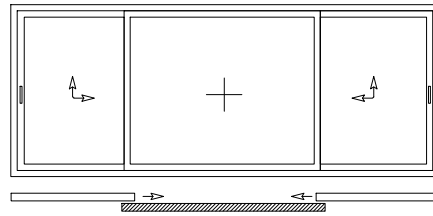

2 HAREKETLİ 1 SABİT KANAT
2 SLIDING 1 FIX SASH

KASA MONTAJ ŞEMASI - FRAME ASSEMBLY SCHEME

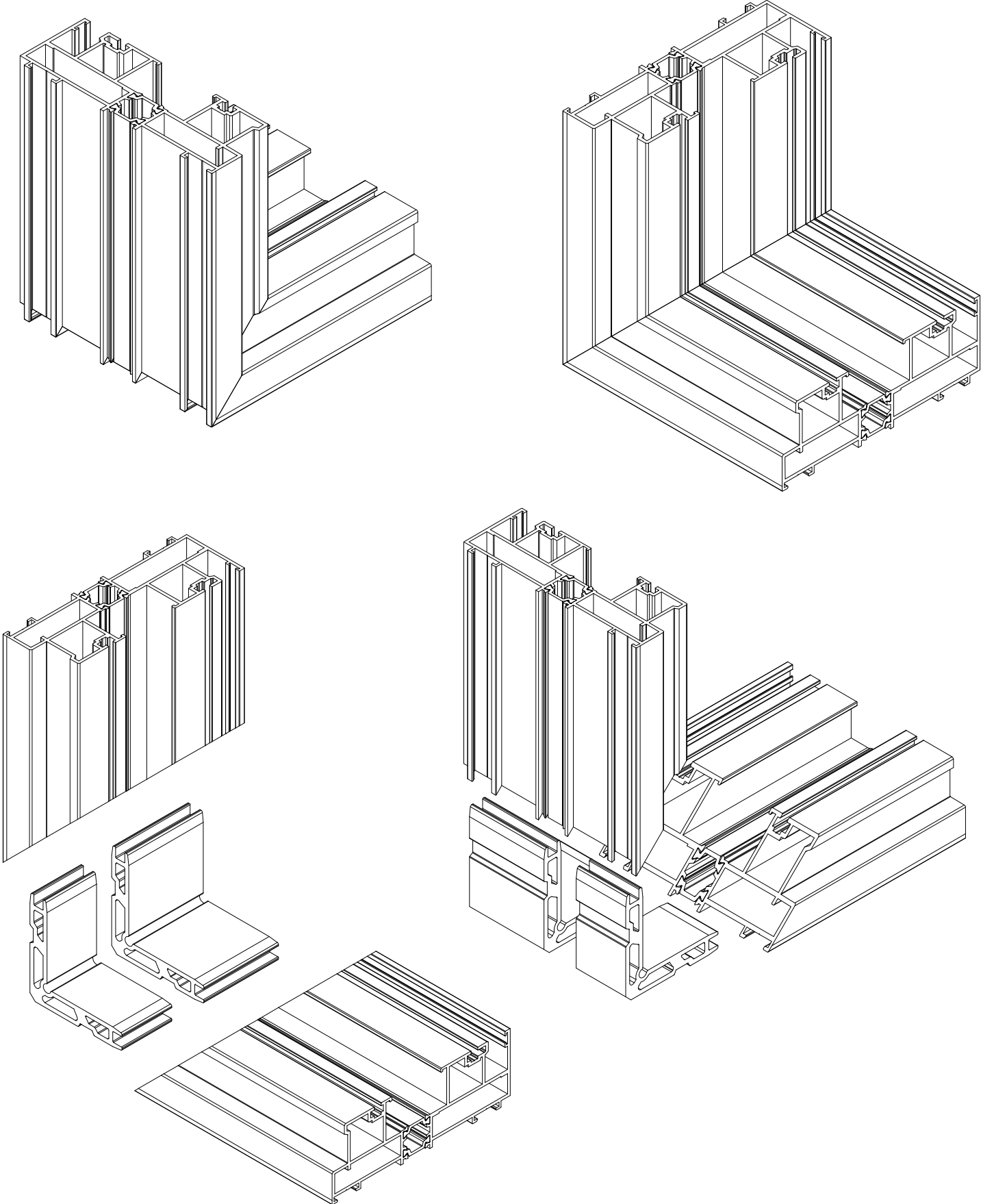

NOT: Profil ağırlıkları teoriktir, üretim sonrası ağırlıklar geçerlidir.

KANAT MONTAJ ŞEMASI - SASH ASSEMBLY SCHEME

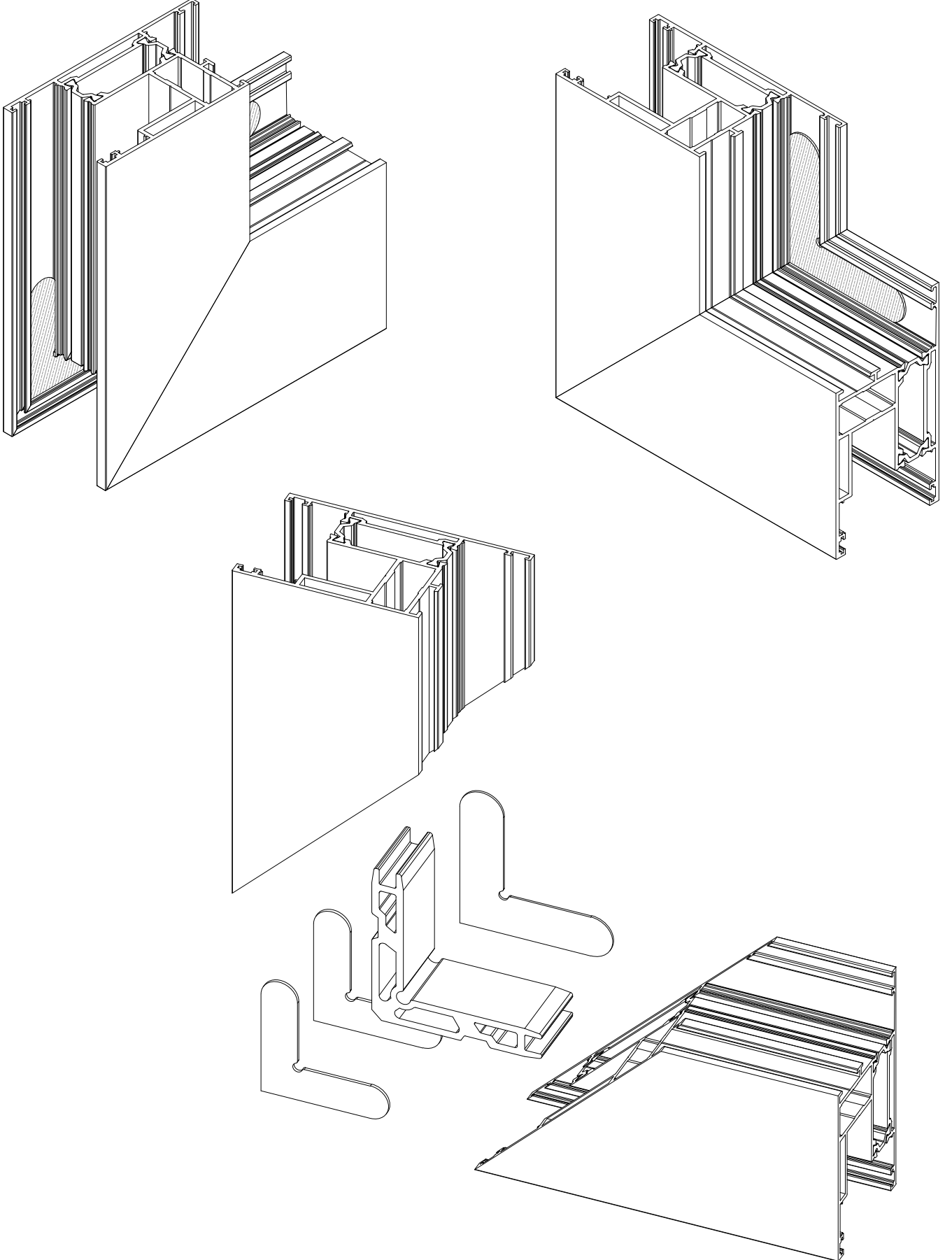

NOT: Profil ağırlıkları teoriktir, üretim sonrası ağırlıklar geçerlidir.

SABİT KANAT MONTAJ ŞEMASI - FIX SAHS ASSEMBLY SCHEME

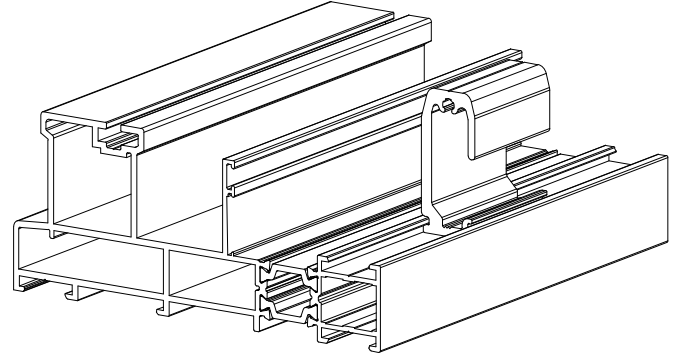
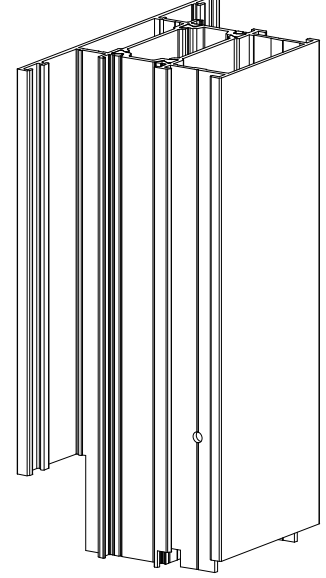
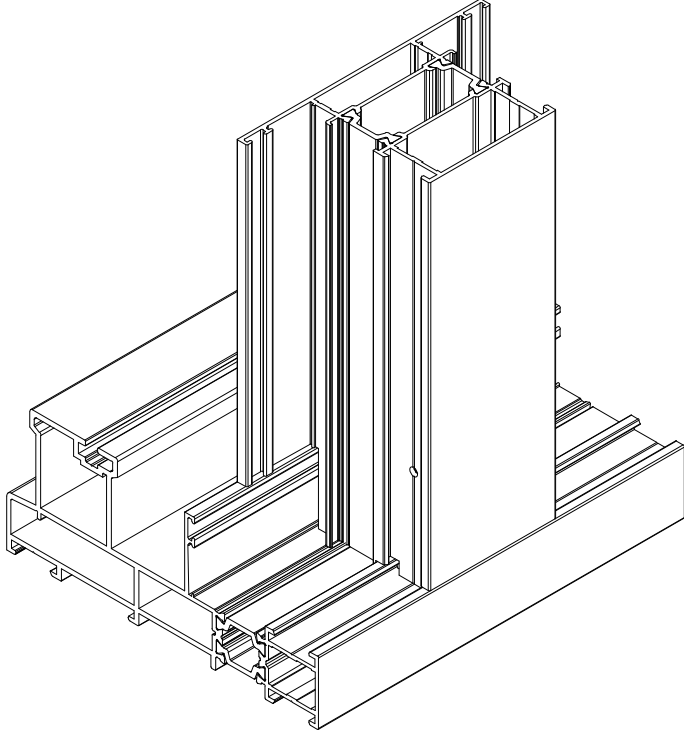

" KERTME MONTAJ ÖLÇÜLERİ "

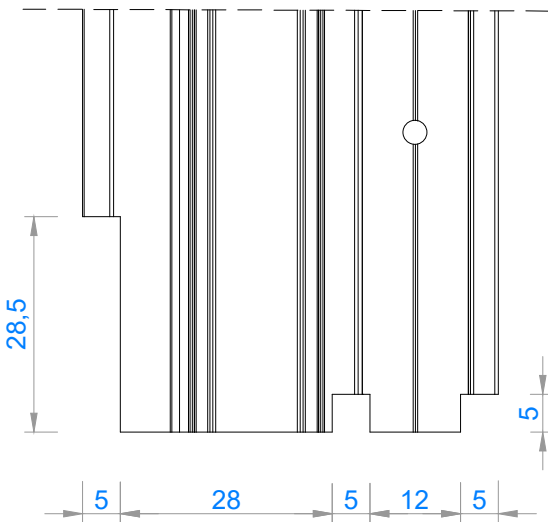

" KÖŞE BİRLEŞTİRME YAPILMADAN "
" TAKILMASI GEREKMEKTEDİR. "

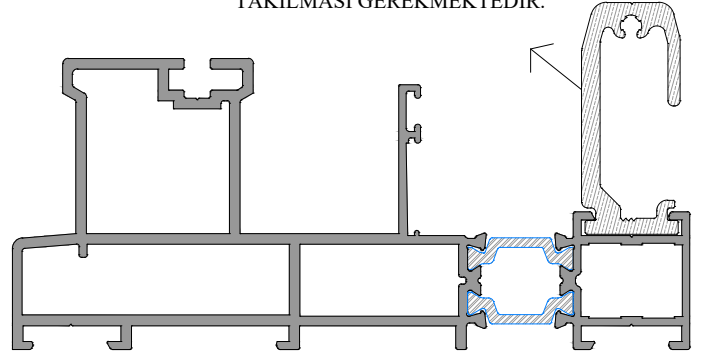

SU TAHLİYE MONTAJ ŞEMASI - WATER EMPTYING ASSEMBLY SCHEME

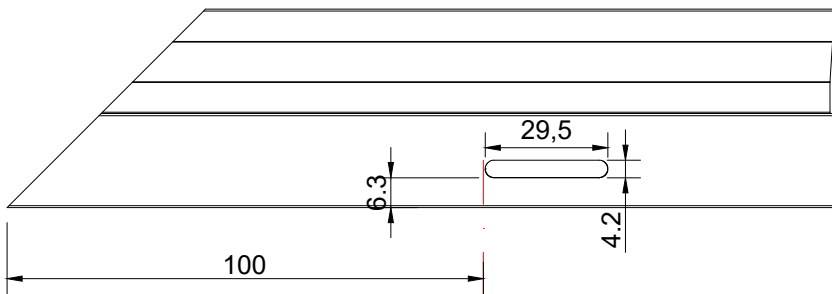
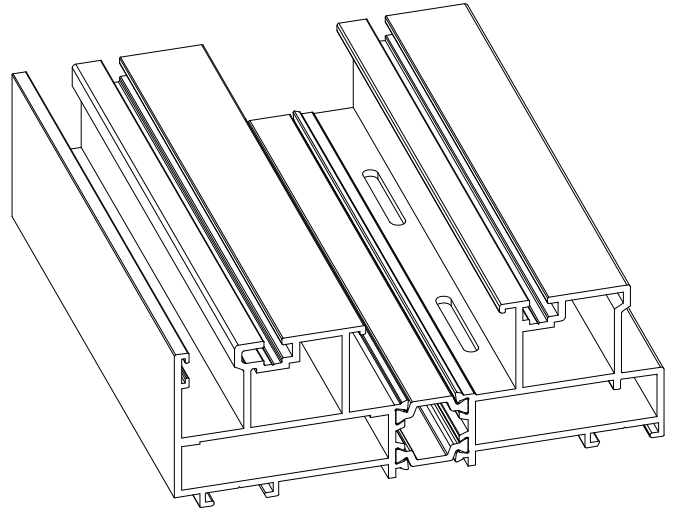
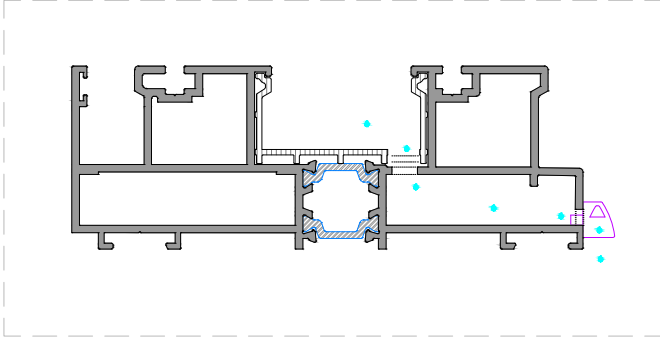
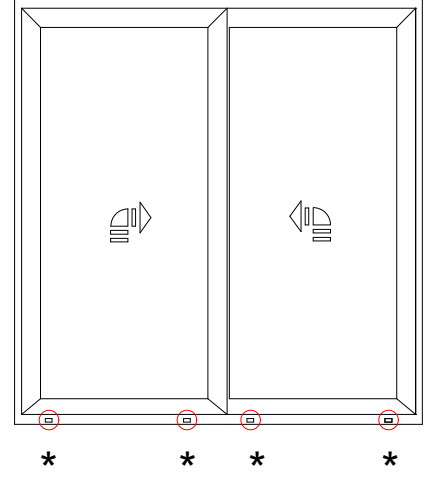
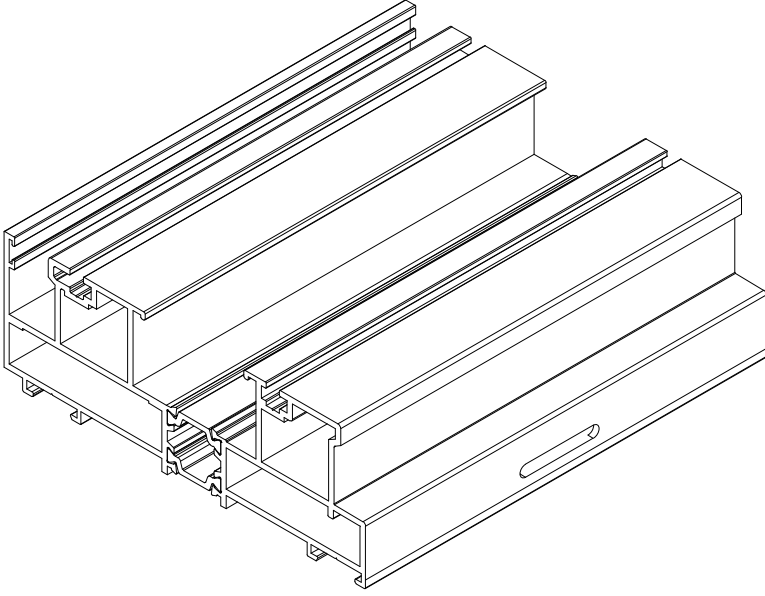

KALDIR & SÜR KOL MONTAJ ŞEMASI - LIFT & SLIDE HANDLE ASSEMBLY SCHEME

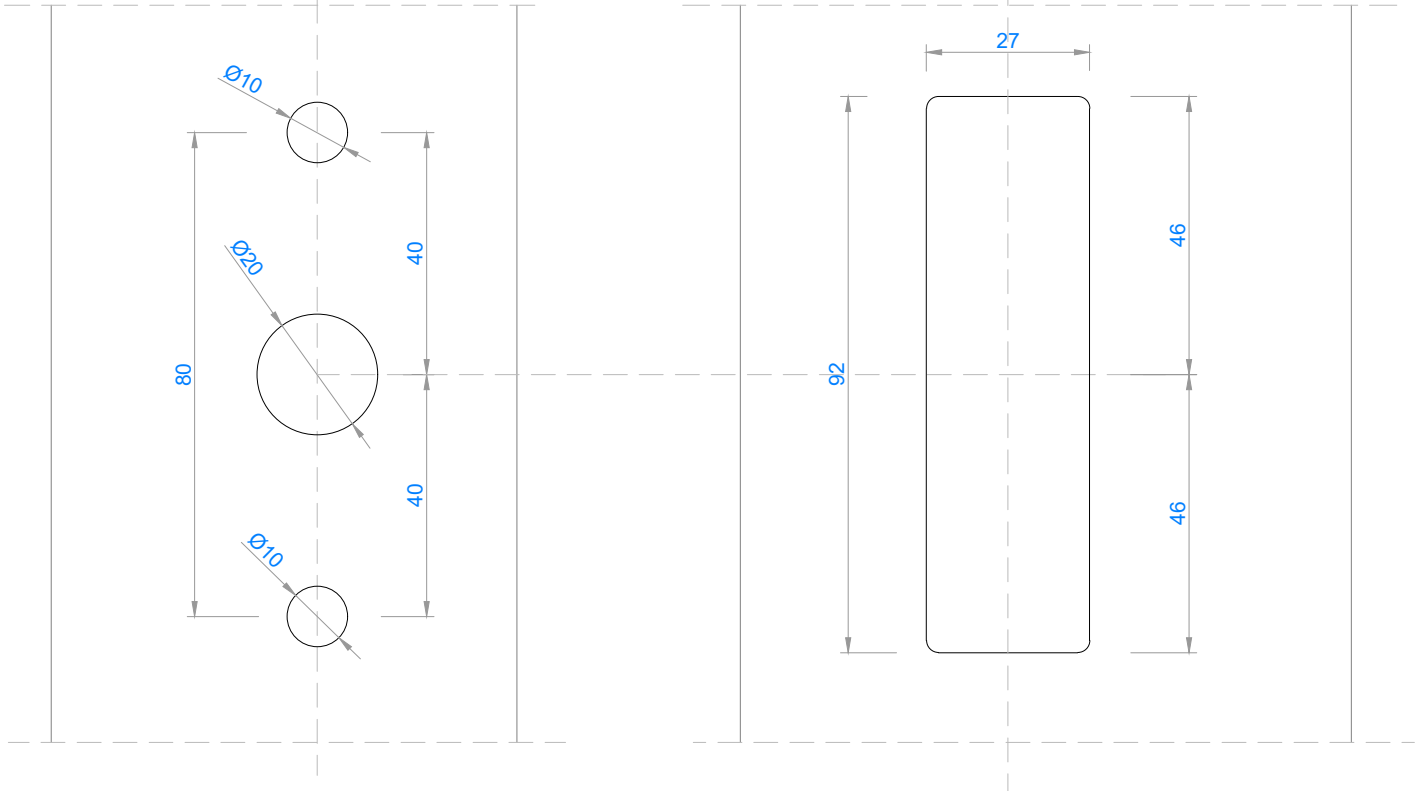
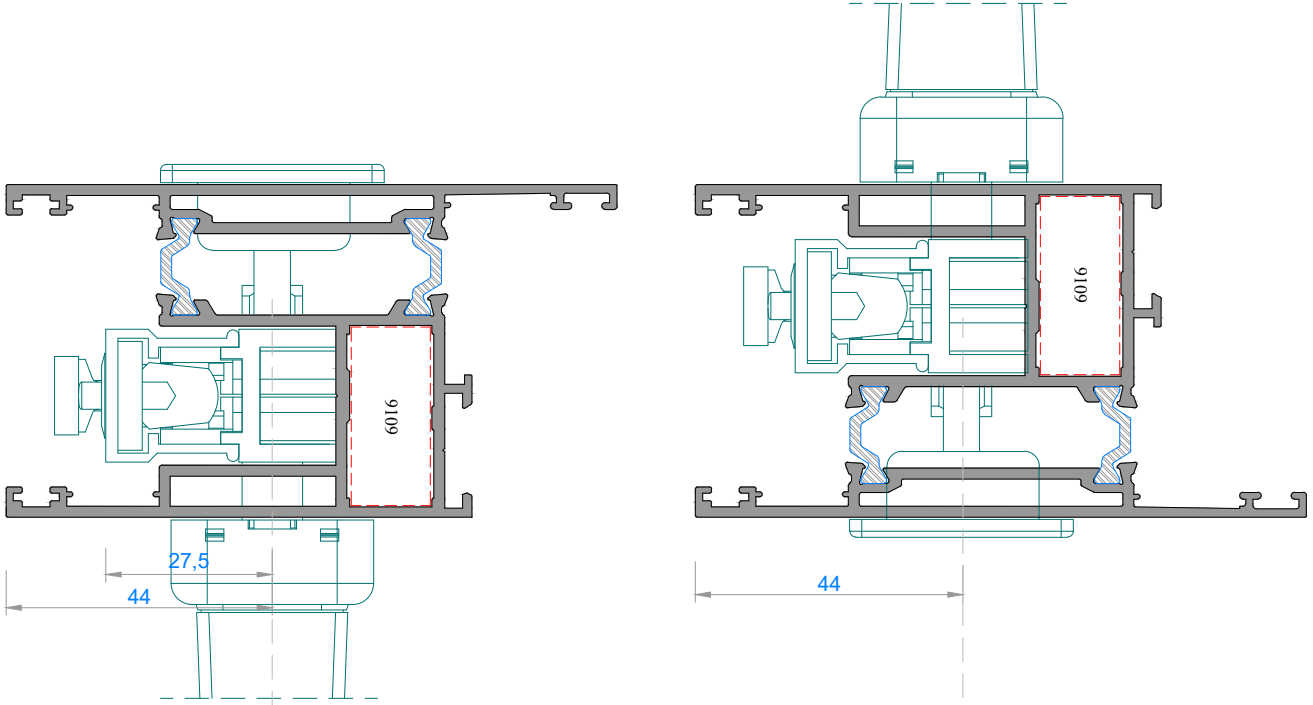

İSPANYOLET KİTLEMELİ NORMAL SÜRME SİSTEMİ - MULTI POINT LOCKING FOR SLIDING SYSTEMS

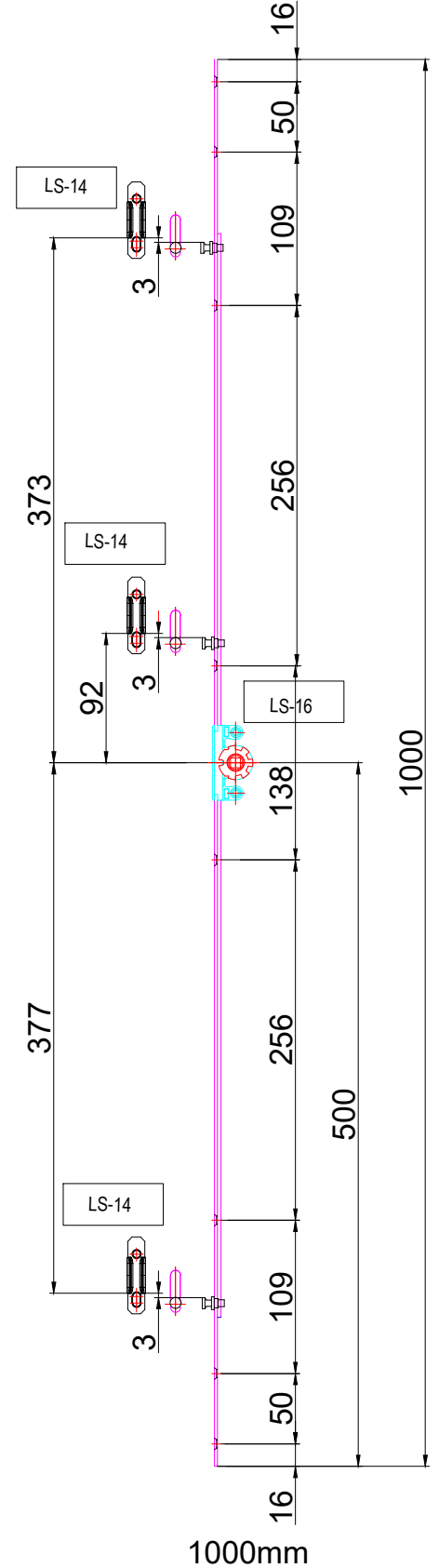
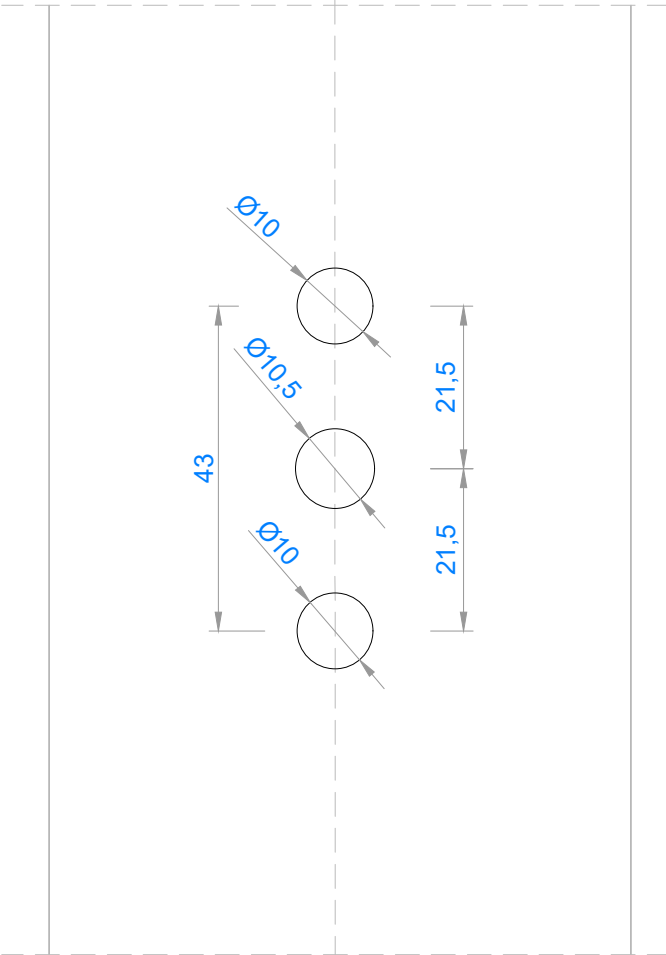
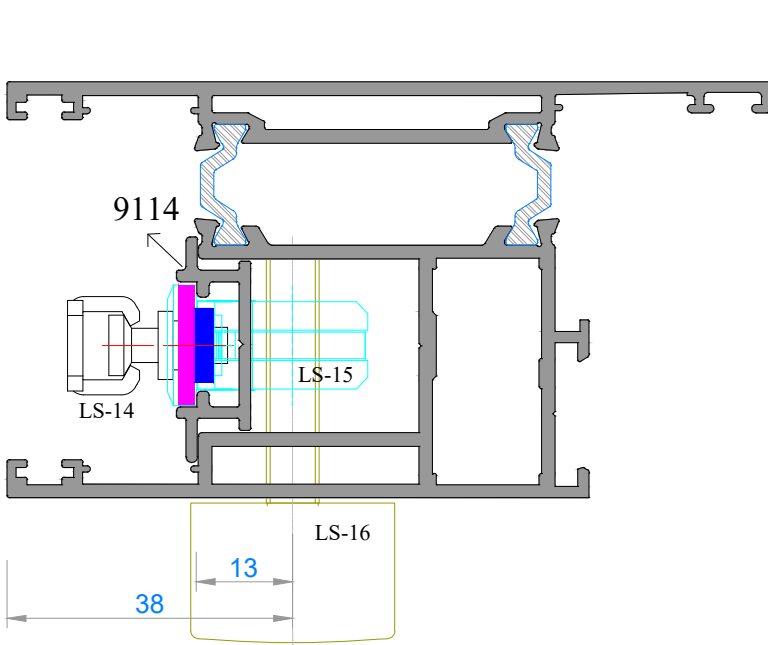

MANUEL SÜRME RULMAN SİSTEMİ - MANUEL SLIDE ROLLER SYSTEMS

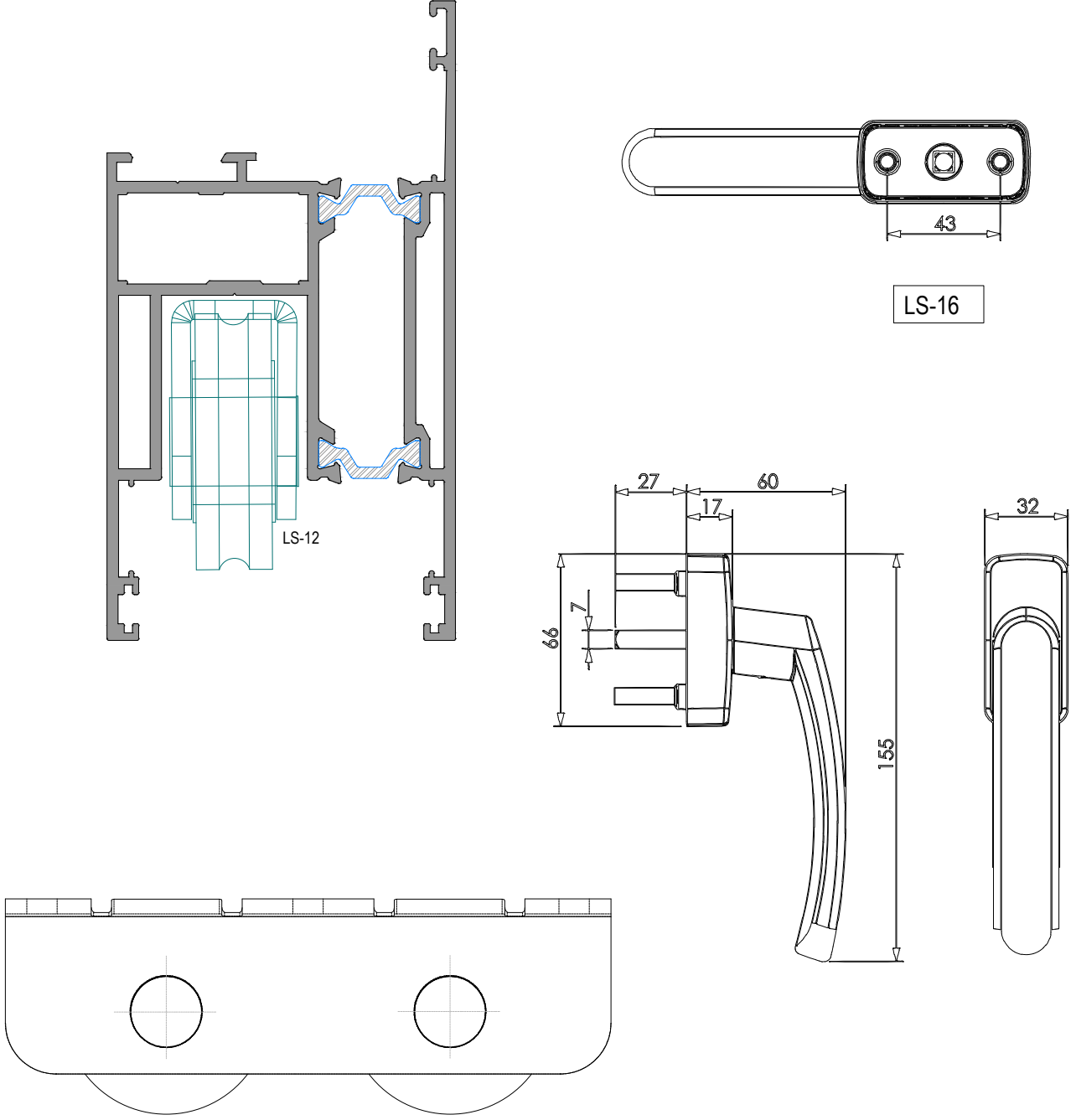

LS-12 - 150 KG

KANAT TAŞIMA KAPASİTESİ : 300 KG

SASH CARRY CAPACITY : 300 KG

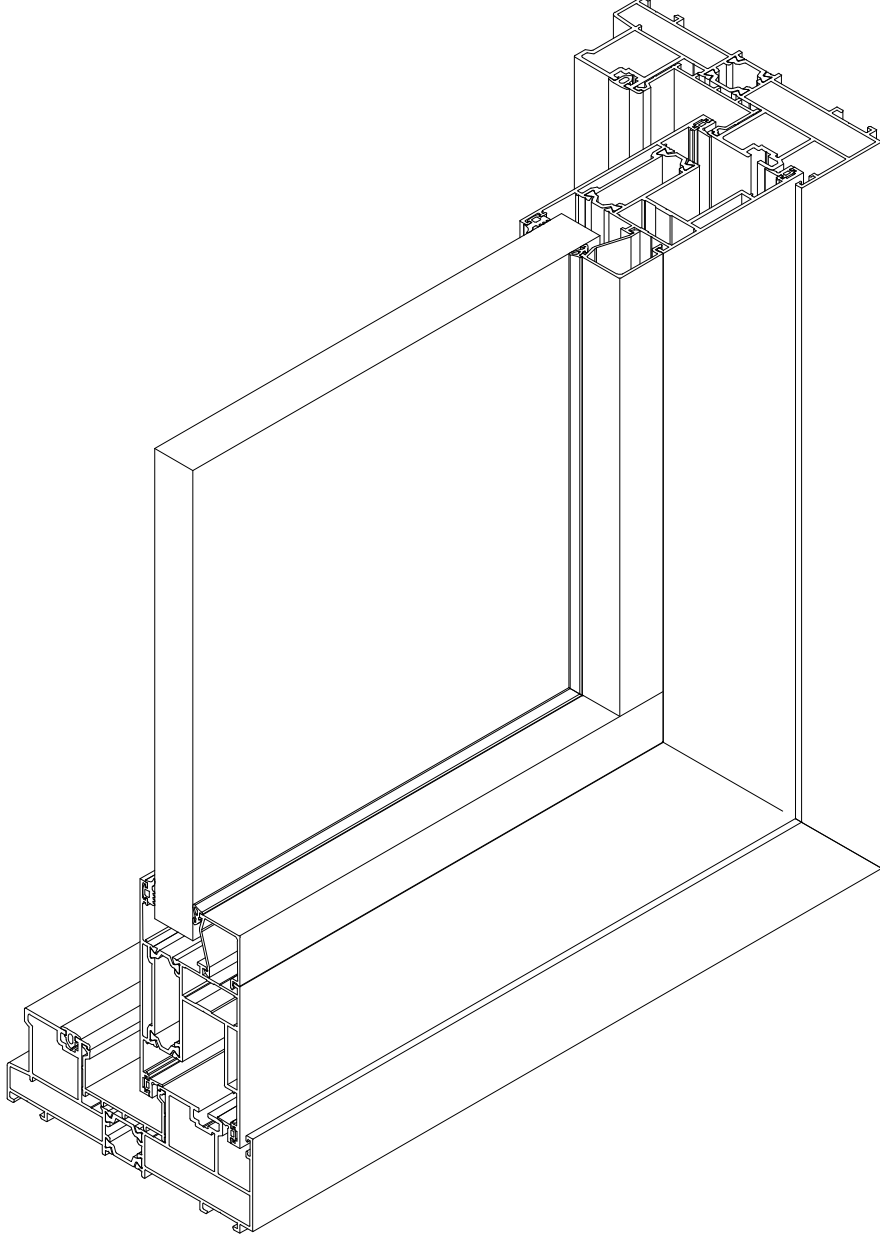
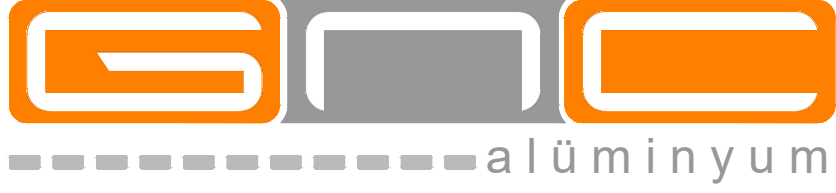





FAUSTO MİMARİ SİSTEMLER

LS-55 AKSESUAR

LS-55 ACCESSORIES

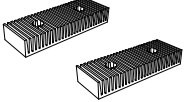
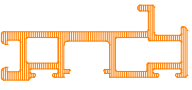
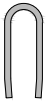
AKSESUAR RESMİ	AKSESUAR KODU	MALZEME	MALZEME TANIMI	AMBALAJ	BİRİM FİYAT
	SC 103 - 1	EPDM	DIŞ CAM CONTASI boşluk : 4mm	12 KG/195 MT	3,70 € / KG
	AYK-04	EPDM	İÇ CAM CONTASI boşluk : 3mm	12 KG/180 MT	3,70 € / KG
	AYK-03	EPDM	İÇ CAM CONTASI boşluk : 4mm	12 KG/170 MT	3,70 € / KG
	AYK-02	EPDM	İÇ CAM CONTASI boşluk : 5mm	12 KG/175 MT	3,70 € / KG
	SC 115	EPDM	KANAT ALT ve YAN BİNİ CONTASI	10 KG/230 MT	3,70 € / KG
	SC 117	EPDM	KANAL KAPAMA CONTASI	330 MT	3,70 € / KG
	SC 118-1	EPDM	KASA KAPAMA PROFİLİ DESTEK CONTASI	10 KG/55 MT	3,70 € / KG
	SC 317-1	EPDM	PVC KENET PROFİLİ İÇ BİNİ CONTASI	12 KG	3,70 € / KG
	SC 318	EPDM	PVC KENET PROFİLİ KANAL KAPAMA CONTASI	10 KG	3,70 € / KG
	LS-09	EPDM	4'LÜ SÜRME ORTA ADAPTÖR CONTASI	12 KG	3,70 € / KG
	LC-1125	INOX	ALYAN KÖŞE CORNER JOINT	250 AD/ 1 KOLİ	₺15,00 / AD
	OB-18X0.9	INOX	KASA ve KANAT İÇİN KÖŞE KÖŞE GÖNYE		0,10 € / AD
	OB-15X1.3	INOX	KANAT İÇİN KÖŞE GÖNYE		0,10 € / AD

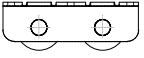
NOT: Profil ağırlıkları teoriktir, üretim sonrası ağırlıklar geçerlidir.

AKSESUAR RESMİ	AKSESUAR KODU	MALZEME	MALZEME TANIMI	AMBALAJ	BİRİM FİYAT
	SC 312	NAYLON	PERDELİ FIRÇA FİTİL	4x300 MT	3,70 € / KG
	SC 313	EPDM	ALT & ÜST SIZDIRMAZLIK PARÇASI	25 TKM	₺17,00 / TKM
	SC 273	PVC	KANAT KAPAMA PROFİLİ SABİT ALT KAPAK	25 TKM	₺21,00 / TKM
	SC 300	PVC	MERKEZİ KANAL PROFİLİ (boy : 6mt)	180MT (6MT x 30AD)	\$0,50 / MT
	SC 330	PVC	MERKEZİ KENET PROFİLİ (boy : 6mt)	180MT (6MT x 30AD)	\$1,10 / MT
	SC 310	INOX	RAY PROFİLİ (boy : 6mt)	60 MT (6 MT x 10 AD)	\$2,40 / MT
	SC 325	PVC	KANAT SABİTLEME TAKOZU (1 kanat için 6ad kullanılır)	50 AD	₺26,00 / AD
	ADA-166-1	INOX	L KÖŞEBENT - L BRACKET	50 AD	₺5,00 / AD
	LS-12	INOX	RULMAN 150 KG KANAT TAŞIMA KAPASİTESİ : 300 KG		3,80 € / AD
	LS-17	INOX	SİNEKLİK RULMAN FLYSCREEN ROLLER		
	LS-16	PVC	KOL HANDLE		4,80 € / AD
	LS-14	INOX	KİLİT KARŞILIĞI LOCK STRIKES		0,19 € / AD

NOT: Profil ağırlıkları teoriktir, üretim sonrası ağırlıklar geçerlidir.

AKSESUAR RESMİ	AKSESUAR KODU	MALZEME	MALZEME TANIMI	AMBALAJ	BİRİM FİYAT
	LS-15		İSPANYOLET KİTLEMELİ NORMAL SÜRME SİSTEMİ MULTIPOINT LOCKING FOR SLIDING SYSTEMS		
	LS-15-400	INOX	400-600/15	ADET	
	LS-15-600	INOX	600-800/15	ADET	
	LS-15-800	INOX	800-1000/15	ADET	
	LS-15-1000	INOX	1000-1200/15	ADET	
	LS-15-1200	INOX	1200-1400/15	ADET	
	LS-15-1400	INOX	1400-1600/15	ADET	
	LS-15-1600	INOX	1600-1800/15	ADET	
	LS-15-1800	INOX	1800-2000/15	ADET	
	LS-15-2000	INOX	2000-3000/15	ADET	

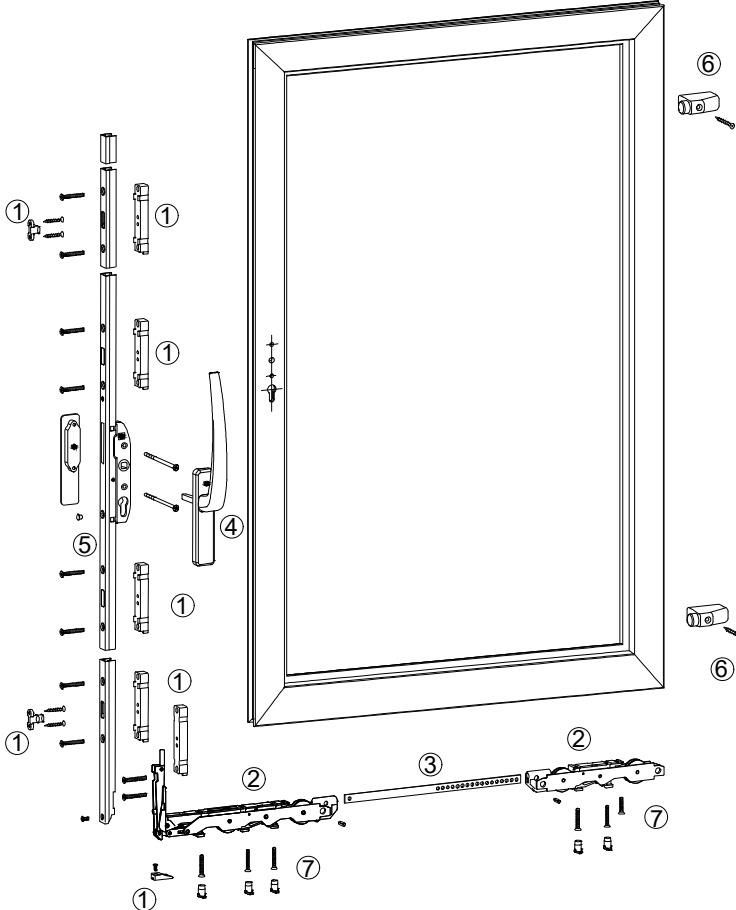
KALDIR & SÜR MEKANİZMASI MONTAJ ŞEMASI
LIFT & SLIDE MECHANISM INSTALLATION SCHEME

LS-08 - Kaldır&Sür Takımı

- 1 - KİTLEME TAKIMI - LOCKING TEAM
- 2 - RULMAN TAKIMI - ROLLER TEAM
- 3 - RULMAN BAĞLANTI ÇUBUĞU - ROLLER CONNECTION ROD
- 4 - KALDIR SÜR KOL - LIFT & AND SLIDE HANDLE
- 5 - İSPANYOLET - MULTI POINT LOCKING
- 6 - STOPER (OPSİYONEL) - STOPPER (OPTIONAL)
- 7 - RULMAN ALT DESTEK - ROLLER SUB SUPPORT